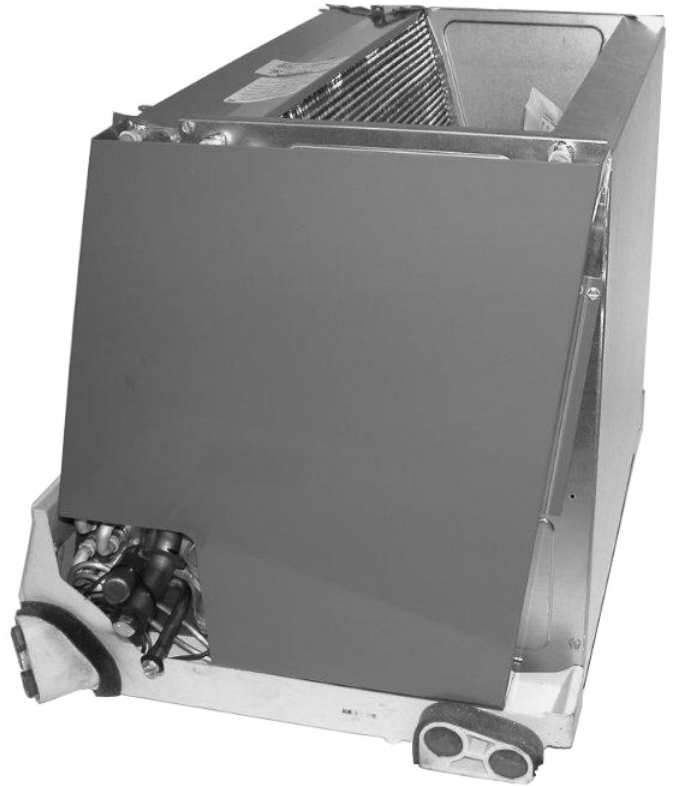


# INSTALLATION INSTRUCTIONS

## FOR CASED/UNCASED COILS FOR GAS FURNACES:

(-)CFZ: Featuring Industry-Standard R-410A  Refrigerant



RECOGNIZE THIS SYMBOL AS AN INDICATION OF IMPORTANT SAFETY INFORMATION!

### **WARNING**

These instructions are intended as an aid to qualified licensed service personnel for proper installation, adjustment and operation of this unit. Read these instructions thoroughly before attempting installation or operation. Failure to follow these instructions may result in improper installation, adjustment, service or maintenance possibly resulting in fire, electrical shock, property damage, personal injury or death.



ISO 9001:2015

**DO NOT DESTROY THIS MANUAL**

**PLEASE READ CAREFULLY AND KEEP IN A SAFE PLACE FOR FUTURE REFERENCE BY A SERVICEMAN**

# TABLE OF CONTENTS

<b>1.0 SAFETY INFORMATION</b> .....	<b>3</b>
<b>2.0. GENERAL INFORMATION</b> .....	<b>4</b>
2.1 INSPECTION .....	4
2.2 CODES/REGULATIONS .....	4
2.3 REPLACEMENT PARTS.....	4
2.4 MODEL NUMBER EXPLANATION.....	5
2.5 COIL SPECIFICATIONS .....	6
2.5A Coil Specifications: Dimensions & Weights (See Figure 2) .....	6
2.5B Coil Specifications: Airflow Pressure Drop .....	7
<b>3.0 INSTALLATION</b> .....	<b>8</b>
3.1 APPLICATIONS .....	8
3.2 REFRIGERANT CONNECTIONS.....	11
3.3 TXV SENSING BULB (TXV COILS ONLY) .....	11
3.4 ELECTRONIC EXPANSION VALVE (EXV).....	11
3.5 EXV VAPOR LINE THERMISTER (EXV COILS ONLY).....	11
3.6 Factory Programmed Superheat (EXV COILS ONLY) .....	13
3.7 SUPERHEAT OFFSET DIP SWITCH SETTINGS (EXV COILS ONLY) .....	13
3.8 EXV Step Dip Switch (EXV COILS ONLY) .....	13
3.9 EXV DIAGNOSTICS (EXV COILS ONLY).....	13
3.10 EXV CONTROL (EXV COILS ONLY).....	14
3.11 EXV CONTROL OPTIONAL MOUNTING LOCATIONS .....	14
3.12 EXV WIRING (EXV COILS ONLY).....	15
3.13 CONDENSATE DRAIN TUBING .....	16
3.14 DUCT FLANGES .....	17
3.15 COIL END SHIELDS.....	17
<b>4.0 MAINTENANCE</b> .....	<b>17</b>
4.1 AIR FILTER .....	17
4.2 INDOOR COIL - DRAIN PAN - DRAIN LINE.....	17
<b>5.0 ACCESSORIES</b> .....	<b>18</b>
5.1 PLENUM ADAPTER ACCESSORY .....	18
5.2 HORIZONTAL ADAPTER KIT RXHH- (See Figure 18 & Table 3).....	19
5.3 EMPTY INDOOR COIL CASING RXBC - (See Figure 19 & Table 4).....	19
5.4 UNCASSED COIL ADAPTER KIT .....	20
5.5 R-22 TXV CONVERSION KITS .....	21

# 1.0 SAFETY INFORMATION

## WARNING

These instructions are intended as an aid to qualified licensed service personnel for proper installation, adjustment and operation of this unit. Read these instructions thoroughly before attempting installation or operation. Failure to follow these instructions may result in improper installation, adjustment, service or maintenance possibly resulting in fire, electrical shock, property damage, personal injury or death.

## WARNING

**PROPOSITION 65:** This appliance contains fiberglass insulation. Respirable particles of fiberglass are known to the State of California to cause cancer.

All manufacturer products meet current Federal OSHA Guidelines for safety. California Proposition 65 warnings are required for certain products, which are not covered by the OSHA standards.

California's Proposition 65 requires warnings for products sold in California that contain or produce any of over 600 listed chemicals known to the State of California to cause cancer or birth defects such as fiberglass insulation, lead in brass, and combustion products from natural gas.

All "new equipment" shipped for sale in California will have labels stating that the product contains and/or produces Proposition 65 chemicals. Although we have not changed our processes, having the same label on all our products facilitates manufacturing and shipping. We cannot always know "when, or if" products will be sold in the California market.

You may receive inquiries from customers about chemicals found in, or produced by, some of our heating and air-conditioning equipment, or found in natural gas used with some of our products. Listed below are those chemicals and substances commonly associated with similar equipment in our industry and other manufacturers.

- Glass Wool (Fiberglass) Insulation
- Carbon Monoxide (CO).
- Formaldehyde
- Benzene

More details are available at the websites for OSHA (Occupational Safety and Health Administration), at [www.osha.gov](http://www.osha.gov) and the State of California's OEHHA (Office of Environmental Health Hazard Assessment), at [www.oehha.org](http://www.oehha.org). Consumer education is important since the chemicals and substances on the list are found in our daily lives. Most consumers are aware that products present safety and health risks, when improperly used, handled and maintained.

## CAUTION

For horizontal applications, the horizontal drain pan must be located under the indoor coil. Failure to place the pan under the coil can result in property damage.

## CAUTION

It is recommended that an auxiliary/secondary drain pan be installed under units containing evaporator coils that are located in any area of a structure where damage to the building or building contents may occur as a result of an overflow of the coil drain pan or a stoppage in the primary condensate drain piping.

## **2.0. GENERAL INFORMATION**

### **2.1 INSPECTION**

Immediately upon receipt, all cartons, and contents should be inspected for transit damage. Units with damaged cartons should be opened immediately. If damage is found, it should be noted on the delivery papers and a damage claim filed with the last carrier. Shipping damage is not covered by the warranty.

- After unit has been delivered to job site, remove carton taking care not to damage unit.
- Check the unit rating plate to be sure equipment matches what is required for the job specification.
- Read the entire instructions before starting the installation. This is particularly important if this is the first installation for this specific model series.
- Many installation steps done prior to installing the unit can save time and simplify the installation.

### **2.2 CODES/REGULATIONS**

Units should be installed in accordance with any local or national codes which may apply. Latest editions are available from: "National Fire Protection Association, Inc., Batterymarch Park, Quincy, MA 02269."

These publications are:

- *ANSI/NFPA Latest Edition (NEC) National Electrical Code.*
- *NFPA90A Installation of Air conditioning and Ventilating Systems.*
- *NFPA90B Installation of Warm Air Heating and Air Conditioning Systems.*

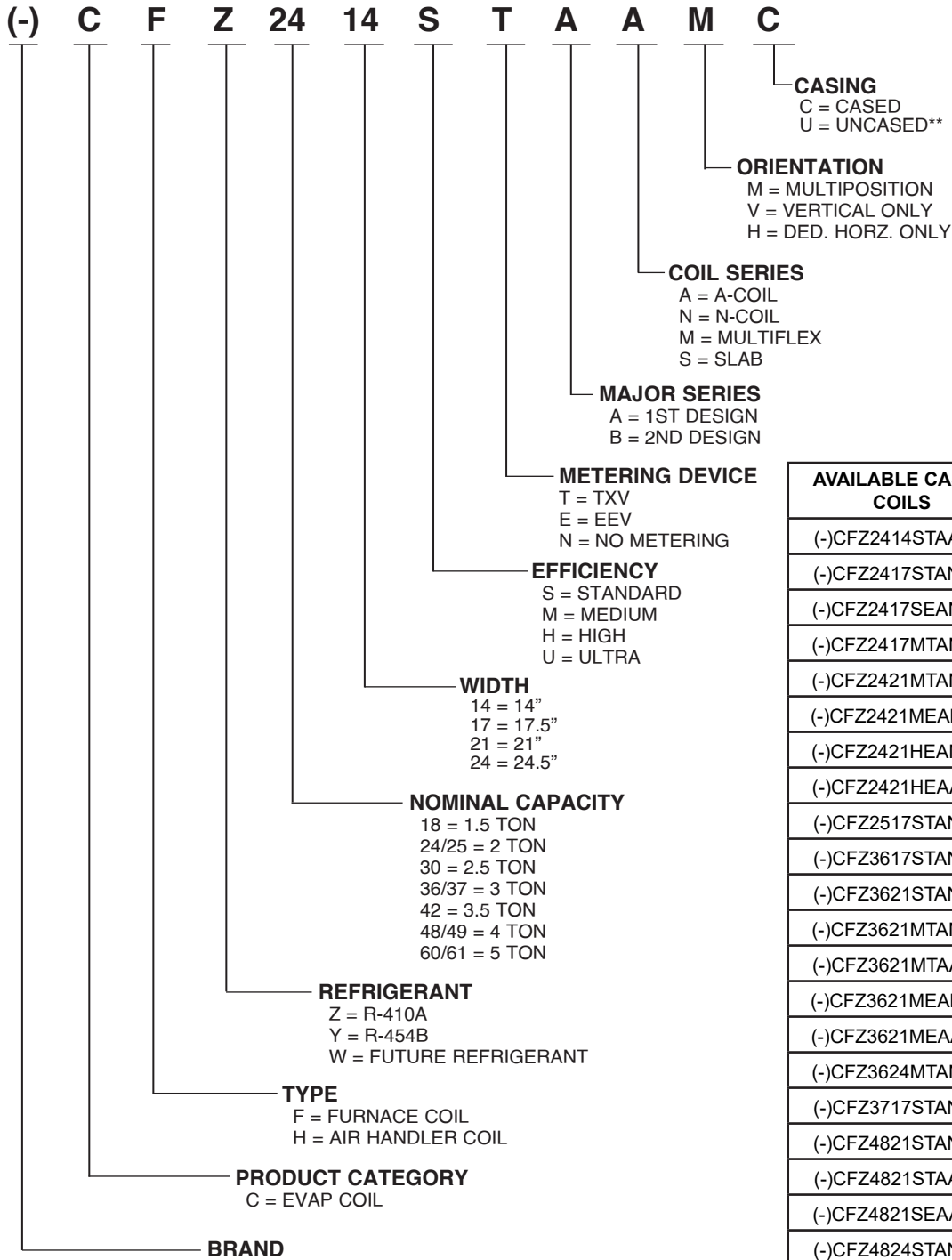
### **2.3 REPLACEMENT PARTS**

Any replacement part must be the same as or an approved alternate to the original part supplied. The manufacturer will not be responsible for replacement parts not designed to physically fit or operate within the design parameters the original parts were selected for.

When ordering replacement parts, it is necessary to order by part number and include the complete model number and serial number from the coil rating plate. (See parts list for unit component part numbers. Parts are available through the local distributor.)

# 2.4 MODEL NUMBER EXPLANATION

**FIGURE 1**  
MODEL NUMBER EXPLANATION

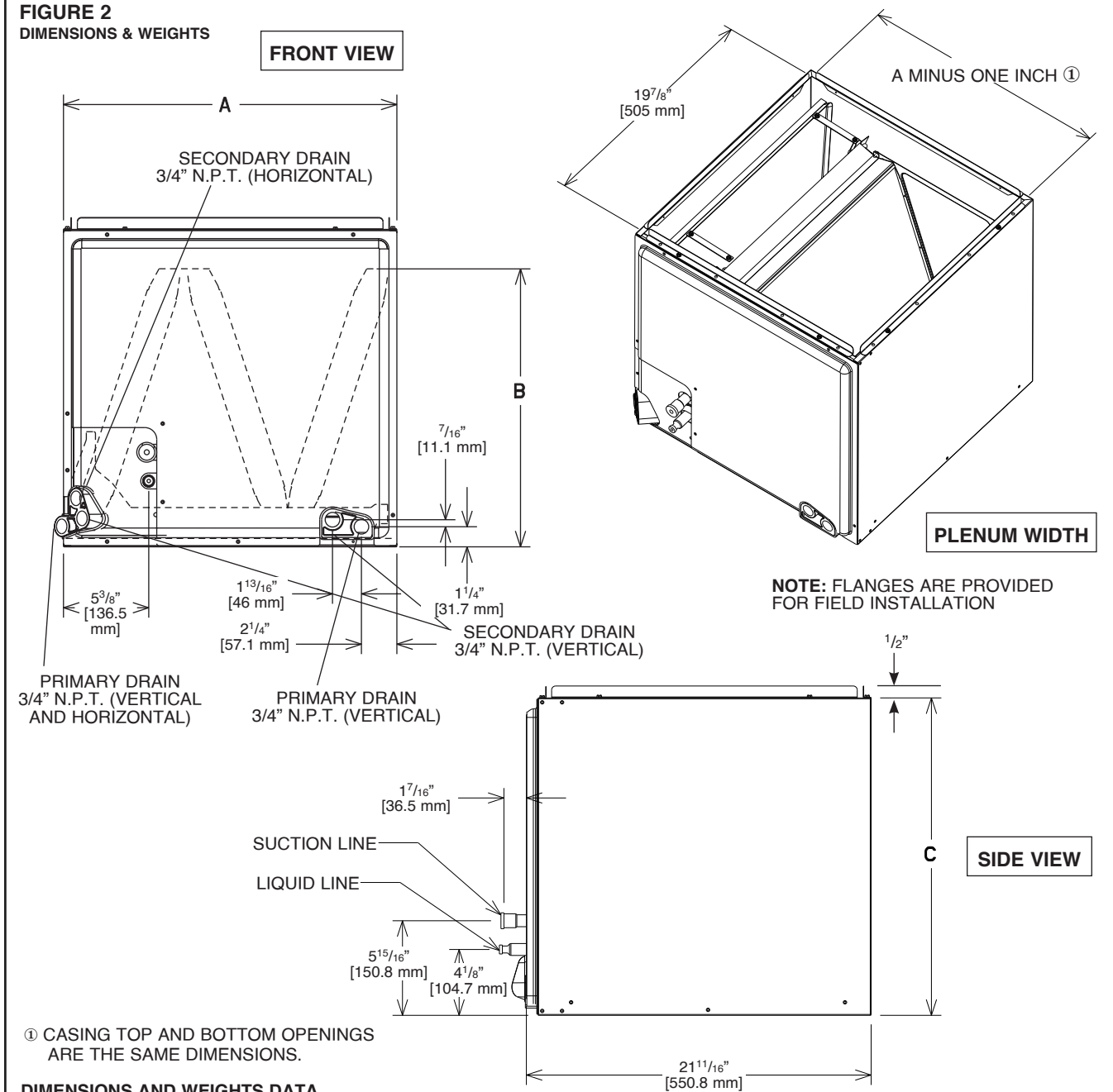


AVAILABLE CASED COILS	AVAILABLE UNCASED COILS
(-)CFZ2414STAAMC	(-)CFZ2414STAAVU
(-)CFZ2417STANMC	(-)CFZ2417STANVU
(-)CFZ2417SEANMC	(-)CFZ2417SEANVU
(-)CFZ2417MTANMC	(-)CFZ2417MTANVU
(-)CFZ2421MTANMC	(-)CFZ2421MTANVU
(-)CFZ2421MEANMC	(-)CFZ2421MEANVU
(-)CFZ2421HEANMC	(-)CFZ2421HEANVU
(-)CFZ2421HEAAMC	(-)CFZ2421HEAAVU
(-)CFZ2517STANMC	(-)CFZ2517STANVU
(-)CFZ3617STANMC	(-)CFZ3617STANVU
(-)CFZ3621STANMC	(-)CFZ3621STANVU
(-)CFZ3621MTANMC	(-)CFZ3621MTANVU
(-)CFZ3621MTAAMC	(-)CFZ3621MTAAVU
(-)CFZ3621MEANMC	(-)CFZ3621MEANVU
(-)CFZ3621MEAAMC	(-)CFZ3621MEAAVU
(-)CFZ3624MTANMC	(-)CFZ3624MTANVU
(-)CFZ3717STANMC	(-)CFZ3717STANVU
(-)CFZ4821STANMC	(-)CFZ4821STANVU
(-)CFZ4821STAAMC	(-)CFZ4821STAAVU
(-)CFZ4821SEAAMC	(-)CFZ4821SEAAVU
(-)CFZ4824STANMC	(-)CFZ4824STANVU
(-)CFZ4824MTANMC	(-)CFZ4824MTANVU
(-)CFZ4921STANMC	(-)CFZ4921STANVU
(-)CFZ6021STAAMC	(-)CFZ6021STAAVU
(-)CFZ6021SEAAMC	(-)CFZ6021SEAAVU
(-)CFZ6024STANMC	(-)CFZ6024STANVU
(-)CFZ6024SEANMC	(-)CFZ6024SEANVU
(-)CFZ6124STANMC	(-)CFZ6124STANVU

\*\*CONVERTIBLE TO HORIZONTAL USING PARTS FROM ORIGINAL COIL OR USING RXHH KIT.

## 2.5 COIL SPECIFICATIONS

### 2.5A Coil Specifications: Dimensions & Weights (See Figure 2)



#### DIMENSIONS AND WEIGHTS DATA

Coil Model (-)CFZ	Connections I.D.		Cased Coil Dimensions (in.) [mm]			Weight	
	Sweat (in) [mm]		A	B	C	Coil Weight (lbs.) [Kg]	Shipping Weight (lbs.) [Kg]
	Liquid	Suction					
2414S*	3/8 [9.53]	3/4 [19.05]	14 [356]	20 1/16 [535]	23 3/16 [584]	45 [20]	49 [22]
2417S / 2517S	3/8 [9.53]	3/4 [19.05]	17 1/2 [445]	14 1/2 [368]	20 [508]	43 [19]	48 [21]
2417M / 3617S / 3717S	3/8 [9.53]	3/4 [19.05]	17 1/2 [445]	17 1/2 [454]	20 [508]	49 [22]	54 [24]
2421M / 3621S	3/8 [9.53]	3/4 [19.05]	21 [533]	17 1/2 [445]	20 [508]	51 [23]	57 [25]
2421H / 3621M / 4821S / 4921S	3/8 [9.53]	7/8 [22.23]	21 [533]	25 5/8 [657]	28 [711]	71 [32]	78 [35]
3624M / 4824S	3/8 [9.53]	7/8 [22.23]	24 1/2 [622]	25 5/8 [645]	32 [812]	83 [38]	93 [42]
4824M / 6024S / 6124S	3/8 [9.53]	7/8 [22.23]	24 1/2 [622]	30 1/4 [768]	32 [812]	100 [45]	110 [50]
2421H* / 3621M* / 4821S* / 6021S*	3/8 [9.53]	7/8 [22.23]	21 [533]	33 [838]	34 1/2 [876]	76 [34]	86 [37]

\* = "A" Coil

## 2.5B Coil Specifications: Airflow Pressure Drop

**TABLE 1**  
**AIRFLOW PRESSURE DROP**

Coil Model	Approx Design Cooling Airflow Range CFM/[L/s]	Face Area Ft <sup>2</sup> [m <sup>2</sup> ]	Fins Per Inch / Rows Deep	Width	Nominal Capacity	CFM [L/s]													
						600 [283]	700 [330]	800 [378]	900 [425]	1000 [472]	1100 [519]	1200 [566]	1300 [614]	1400 [661]	1500 [708]	1600 [755]	1700 [802]	1800 [850]	1900 [897]
						Wet Coil Static Pressure Drop (Inches W.C.) [Pa] - Coil Only													
(-)CFZ2414S*	525/900 [248/425]	4.56 [0.42]	16/2	14	1.5 - 2	0.171 [42]	0.221 [55]	0.278 [69]	0.342 [85]	0.412 [103]	--	--	--	--	--	--	--	--	
(-)CFZ2417S/ (-)CFZ2517S	525/900 [248/425]	4.56 [0.42]	16/2	17		0.115 [29]	0.150 [37]	0.189 [47]	0.232 [58]	0.279 [69]	--	--	--	--	--	--	--	--	
(-)CFZ2417M	525/900 [248/425]	5.70 [0.52]	16/2		2.5 - 3	0.107 [27]	0.137 [34]	0.171 [42]	0.209 [52]	0.251 [62]	--	--	--	--	--	--	--	--	
(-)CFZ3617S/ (-)CFZ3717S	800/1200 [378/566]	5.70 [0.52]	16/2	21		0.107 [27]	0.137 [34]	0.171 [42]	0.209 [52]	0.251 [62]	0.297 [74]	0.347 [86]	0.401 [100]	--	--	--	--	--	
(-)CFZ2421M	525/900 [248/425]	5.70 [0.52]	16/2		1.5 - 2	0.107 [27]	0.137 [34]	0.171 [42]	0.209 [52]	0.251 [62]	--	--	--	--	--	--	--	--	
(-)CFZ2421H	525/900 [248/425]	8.55 [0.79]	16/2			0.062 [15]	0.086 [21]	0.112 [28]	0.140 [35]	0.170 [42]	--	--	--	--	--	--	--	--	
(-)CFZ2421H*	525/900 [248/425]	7.60 [0.70]	13/3			0.041 [10]	0.060 [15]	0.081 [20]	0.105 [26]	0.130 [32]	--	--	--	--	--	--	--	--	
(-)CFZ3621S	800/1200 [378/566]	5.70 [0.52]	16/2		2.5 - 3	0.107 [27]	0.137 [34]	0.171 [42]	0.209 [52]	0.251 [62]	0.297 [74]	0.347 [86]	0.401 [100]	--	--	--	--	--	
(-)CFZ3621M	800/1300 [378/614]	8.55 [0.79]	16/2			0.062 [15]	0.086 [21]	0.112 [28]	0.140 [35]	0.170 [42]	0.202 [50]	0.236 [59]	0.272 [68]	0.309 [77]	--	--	--	--	
(-)CFZ3621M*	800/1300 [378/614]	7.60 [0.70]	13/3			0.041 [10]	0.060 [15]	0.081 [20]	0.105 [26]	0.130 [32]	0.157 [39]	0.186 [46]	0.217 [54]	0.250 [62]	--	--	--	--	
(-)CFZ4821S/ (-)CFZ4921S	1200/1600 [566/755]	8.55 [0.79]	16/2		3.5 - 4	0.062 [15]	0.086 [21]	0.112 [28]	0.140 [35]	0.170 [42]	0.202 [50]	0.236 [59]	0.272 [68]	0.309 [77]	0.349 [87]	0.391 [97]	0.434 [108]	0.480 [119]	--
(-)CFZ4821S*	1200/1600 [566/755]	7.60 [0.70]	13/3			0.041 [10]	0.060 [15]	0.081 [20]	0.105 [26]	0.130 [32]	0.157 [39]	0.186 [46]	0.217 [54]	0.250 [62]	0.285 [71]	0.322 [80]	0.361 [90]	0.402 [100]	--
(-)CFZ6021S*	1400/1800 [661/850]	7.60 [0.70]	13/3			5	0.000 [0]	0.007 [2]	0.035 [9]	0.063 [16]	0.091 [23]	0.119 [30]	0.147 [37]	0.175 [44]	0.203 [50]	0.231 [57]	0.259 [64]	0.287 [71]	0.315 [78]
(-)CFZ6021SE*	1400/1800 [661/755]	7.60 [0.70]	13/3		3 - 5	0.041 [10]	0.060 [15]	0.081 [20]	0.105 [26]	0.130 [32]	0.157 [39]	0.186 [46]	0.217 [54]	0.250 [62]	0.285 [71]	0.322 [80]	0.361 [90]	0.402 [100]	0.444 [111]
(-)CFZ3624M	800/1300 [378/614]	8.55 [0.79]	16/2		24	2.5 - 3	0.062 [15]	0.086 [21]	0.112 [28]	0.140 [35]	0.170 [42]	0.202 [50]	0.236 [59]	0.272 [68]	0.309 [77]	--	--	--	--
(-)CFZ4824S	1200/1600 [566/755]	8.55 [0.79]	16/2	0.062 [15]			0.086 [21]	0.112 [28]	0.140 [35]	0.170 [42]	0.202 [50]	0.236 [59]	0.272 [68]	0.309 [77]	0.349 [87]	0.391 [97]	0.434 [108]	0.480 [119]	--
(-)CFZ4824M	1200/1600 [566/755]	9.98 [0.93]	14/3	3.5 - 4		0.032 [8]	0.049 [12]	0.069 [17]	0.091 [23]	0.114 [28]	0.140 [35]	0.167 [42]	0.197 [49]	0.228 [57]	0.262 [65]	0.297 [74]	0.334 [83]	0.374 [93]	--
(-)CFZ6024S/ (-)CFZ6124S	1400/1600 [661/755]	9.98 [0.93]	14/3			5	0.032 [8]	0.049 [12]	0.069 [17]	0.091 [23]	0.114 [28]	0.140 [35]	0.167 [42]	0.197 [49]	0.228 [57]	0.262 [65]	0.297 [74]	0.334 [83]	0.374 [93]

Coil Model	Approx Design Cooling Airflow Range CFM/[L/s]	Face Area Ft <sup>2</sup> [m <sup>2</sup> ]	Fins Per Inch / Rows Deep	Width	Nominal Capacity	CFM [L/s]													
						600 [283]	700 [330]	800 [378]	900 [425]	1000 [472]	1100 [519]	1200 [566]	1300 [614]	1400 [661]	1500 [708]	1600 [755]	1700 [802]	1800 [850]	1900 [897]
						Dry Coil Static Pressure Drop (Inches W.C.) [Pa] - Coil Only													
(-)CFZ2414S*	600/1200 [283/566]	4.56 [0.42]	16/2	14	1.5-2	0.121 [30]	0.160 [40]	0.205 [51]	0.256 [64]	0.312 [78]	0.373 [93]	0.441 [110]	0.514 [128]	--	--	--	--	--	
(-)CFZ2417S/ (-)CFZ2517S	600/1200 [283/566]	4.56 [0.42]	16/2	17		0.097 [24]	0.128 [32]	0.163 [41]	0.202 [50]	0.245 [61]	0.292 [73]	0.343 [85]	0.398 [99]	--	--	--	--	--	
(-)CFZ2417M	600/1200 [283/566]	5.70 [0.52]	16/2		2.5-3	0.112 [28]	0.144 [36]	0.180 [45]	0.220 [55]	0.264 [66]	0.312 [78]	0.364 [91]	0.420 [105]	--	--	--	--	--	
(-)CFZ3617S/ (-)CFZ3717S	600/1300 [283/614]	5.70 [0.52]	16/2	0.112 [28]		0.144 [36]	0.180 [45]	0.220 [55]	0.264 [66]	0.312 [78]	0.364 [91]	0.420 [105]	0.480 [119]	--	--	--	--	--	
(-)CFZ2421M	600/1200 [283/566]	5.70 [0.52]	16/2	1.5-2	0.112 [28]	0.144 [36]	0.180 [45]	0.220 [55]	0.264 [66]	0.312 [78]	0.364 [91]	0.420 [105]	--	--	--	--	--		
(-)CFZ2421H	600/1200 [283/566]	8.55 [0.79]	16/2		0.062 [15]	0.086 [21]	0.112 [28]	0.140 [35]	0.170 [42]	0.202 [50]	0.236 [59]	0.272 [68]	0.309 [77]	0.349 [87]	0.391 [97]	0.434 [108]	--	--	
(-)CFZ2421H*	600/1600 [283/755]	7.60 [0.70]	13/3		0.043 [11]	0.053 [13]	0.066 [16]	0.080 [20]	0.096 [24]	0.115 [29]	0.135 [34]	0.158 [39]	0.182 [45]	0.208 [52]	0.237 [59]	0.267 [66]	--	--	
(-)CFZ3621S	600/1400 [283/661]	5.70 [0.52]	16/2	2.5-3	0.112 [28]	0.144 [36]	0.180 [45]	0.220 [55]	0.264 [66]	0.312 [78]	0.364 [91]	0.420 [105]	0.480 [119]	--	--	--	--		
(-)CFZ3621M	600/1900 [283/897]	8.55 [0.79]	16/2		0.039 [10]	0.056 [14]	0.075 [19]	0.095 [24]	0.117 [29]	0.141 [35]	0.166 [41]	0.193 [48]	0.222 [55]	0.252 [63]	0.284 [71]	0.318 [79]	0.353 [88]	0.391 [97]	
(-)CFZ3621M*	600/1900 [283/897]	7.60 [0.70]	13/3		0.043 [11]	0.053 [13]	0.066 [16]	0.080 [20]	0.096 [24]	0.115 [29]	0.135 [34]	0.158 [39]	0.182 [45]	0.208 [52]	0.237 [59]	0.267 [66]	0.299 [75]	0.334 [83]	
(-)CFZ4821S/ (-)CFZ4921S	600/1900 [283/897]	8.55 [0.79]	16/2	3.5-4	0.039 [10]	0.056 [14]	0.075 [19]	0.095 [24]	0.117 [29]	0.141 [35]	0.166 [41]	0.193 [48]	0.222 [55]	0.252 [63]	0.284 [71]	0.318 [79]	0.353 [88]	0.391 [97]	
(-)CFZ4821S*	600/1900 [283/897]	7.60 [0.70]	13/3		0.043 [11]	0.053 [13]	0.066 [16]	0.080 [20]	0.096 [24]	0.115 [29]	0.135 [34]	0.158 [39]	0.182 [45]	0.208 [52]	0.237 [59]	0.267 [66]	0.299 [75]	0.334 [83]	
(-)CFZ6021S*	600/1900 [283/897]	7.60 [0.70]	13/3		5	0.000 [0]	0.000 [0]	0.016 [4]	0.040 [10]	0.065 [16]	0.089 [22]	0.113 [28]	0.137 [34]	0.162 [40]	0.186 [46]	0.210 [52]	0.234 [58]	0.259 [64]	0.283 [70]
(-)CFZ6021SE*	600/1900 [283/897]	7.60 [0.70]	13/3	3-5	0.043 [11]	0.053 [13]	0.066 [16]	0.080 [20]	0.096 [24]	0.115 [29]	0.135 [34]	0.158 [39]	0.182 [45]	0.208 [52]	0.237 [59]	0.267 [66]	0.299 [75]	0.334 [83]	
(-)CFZ3624M	600/1900 [283/897]	8.55 [0.79]	16/2	24	2.5-3	0.039 [10]	0.056 [14]	0.075 [19]	0.095 [24]	0.117 [29]	0.141 [35]	0.166 [41]	0.193 [48]	0.222 [55]	0.252 [63]	0.284 [71]	0.318 [79]	0.353 [88]	0.391 [97]
(-)CFZ4824S	600/1900 [283/897]	8.55 [0.79]	16/2			0.039 [10]	0.056 [14]	0.075 [19]	0.095 [24]	0.117 [29]	0.141 [35]	0.166 [41]	0.193 [48]	0.222 [55]	0.252 [63]	0.284 [71]	0.318 [79]	0.353 [88]	0.391 [97]
(-)CFZ4824M	600/1900 [283/897]	9.98 [0.93]	14/3		3.5-4	0.023 [6]	0.038 [10]	0.055 [14]	0.074 [18]	0.095 [24]	0.119 [29]	0.144 [36]	0.171 [42]	0.200 [50]	0.231 [58]	0.264 [66]	0.300 [75]	0.337 [84]	0.376 [94]
(-)CFZ6024S/ (-)CFZ6124S	600/1900 [283/897]	9.98 [0.93]	14/3			5	0.023 [6]	0.038 [10]	0.055 [14]	0.074 [18]	0.095 [24]	0.119 [29]	0.144 [36]	0.171 [42]	0.200 [50]	0.231 [58]	0.264 [66]	0.300 [75]	0.337 [84]

[ ] Designates Metric Conversion

**IMPORTANT NOTE:** Gas furnace heating CFM can exceed the design cooling CFM. Ductwork and coil selection must accommodate the higher of the cooling or gas heating CFM to prevent furnace limit tripping, excessive noise, and coil freeze-up.

\* = "A" COIL

# 3.0 INSTALLATION

## 3.1 APPLICATIONS

(-)CFZ cased coils can be applied in upflow, downflow, horizontal right and horizontal left applications without modifications. (-)CFZ uncased coils can only be applied in upflow and downflow applications as received (see Table 2 and Figure 3 and 4). For horizontal applications of uncased replacement coils, installation of a horizontal drip shield and water management parts from old coil is required or an RXHH Horizontal Adapter Kit may be used. (See Section 5.2: Horizontal Adapter Kit.)

For coils that are **two** sizes larger than the furnace, for example, a 21" wide coil on a 14" furnace, a tapered adaptor with a minimum height of 6" is required to evenly distribute airflow. See Figure 6. For coils that are **one** size larger than the furnace; for example a 21" wide coil on a 17½" furnace, seal the gap between the two units with sheet metal, or use the specified adaptor kit (RXBA-AC). See Figure 7.

### CAUTION

**For horizontal applications, the horizontal drain pan must be located under the indoor coil. Failure to place the pan under the coil can result in property damage.**

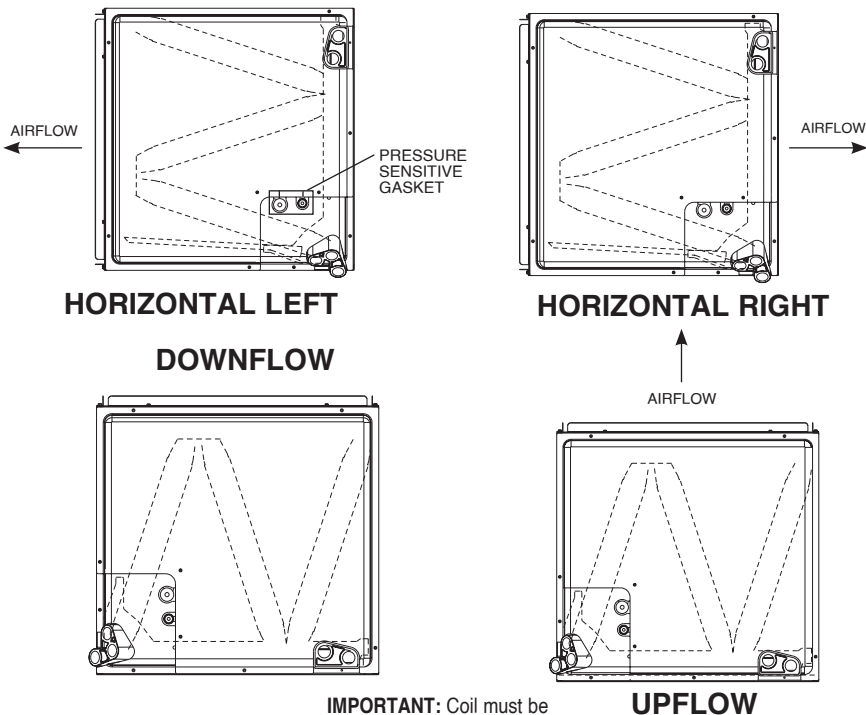
**TABLE 2**

**COIL APPLICATION**

Coil Model (-)CFZ	Furnace Width (In.) [mm]	
	Oil*	Gas
2414S / 2417S / 2417M / 2517S / 3617S / 3717S	—	14 [356]
2417S / 2417M / 2517S / 3617S / 3717S	17 [431]	17½ [444]
		14 [356]
2421M / 2421H / 3621S / 3621M / 4821S / 4921S / 6021S	21 [533]	21 [533]
		17½ [444]
3624M / 4824S / 4824M / 6024S / 6024H / 6124S	24½ [622]	24½ [622]
		21 [533]

\*Due to the proximity of the drain pan to the high temperature oil furnace drum, **horizontal left** application is **NOT** permitted on all oil furnaces.

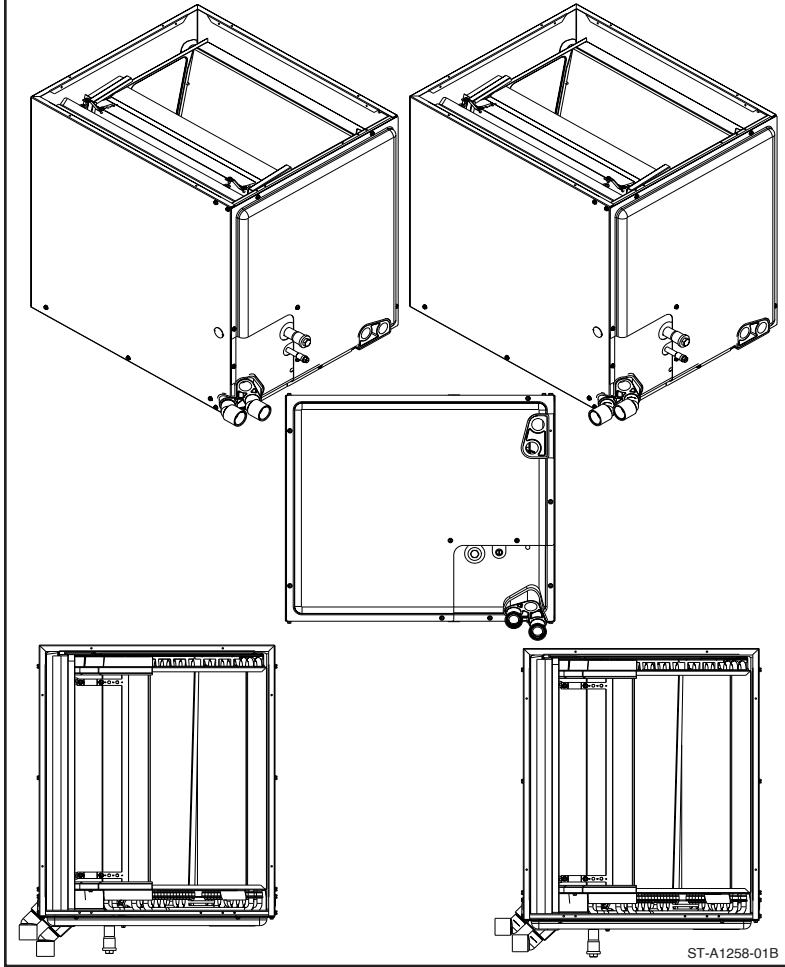
**FIGURE 3**  
COIL INSTALLATION OPTIONS



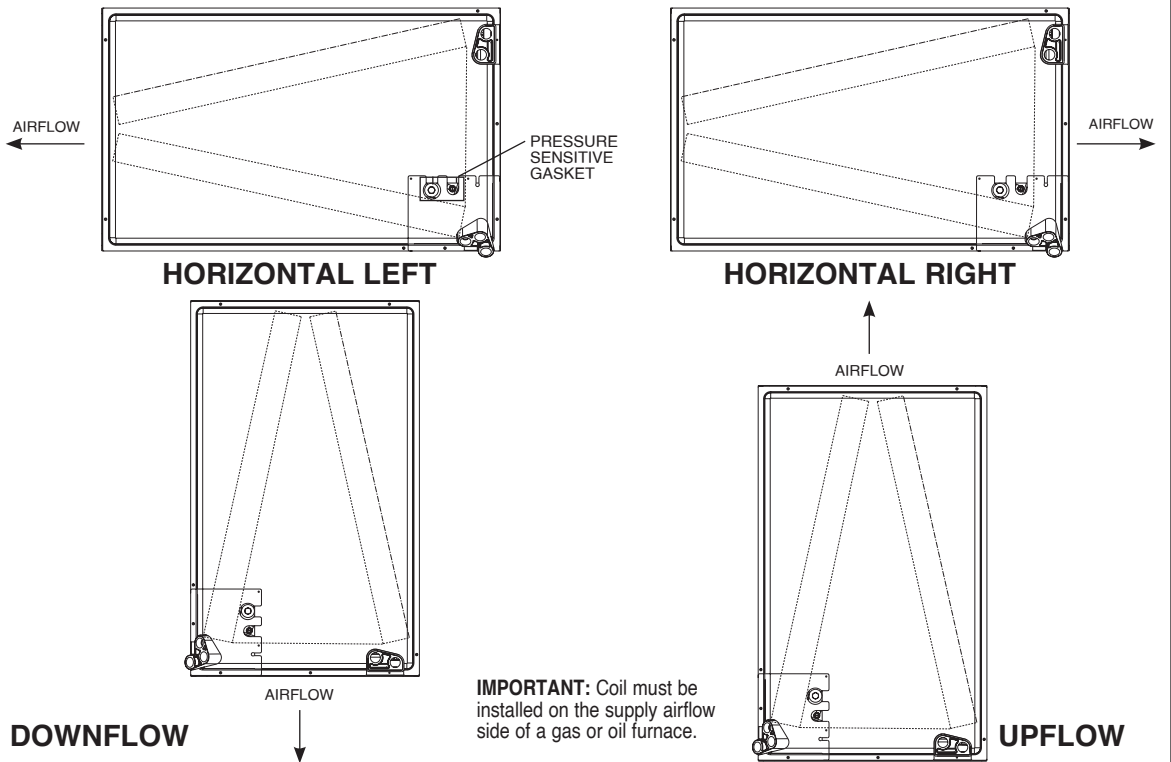
**IMPORTANT:** Coil must be installed on the supply airflow side of a gas or oil furnace.



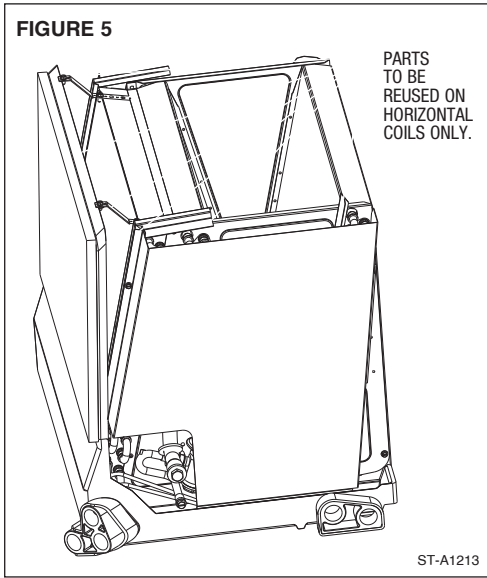
**FIGURE 3B**  
**COIL INSTALLATION OPTIONS WITH 45° STREET ELBOW**



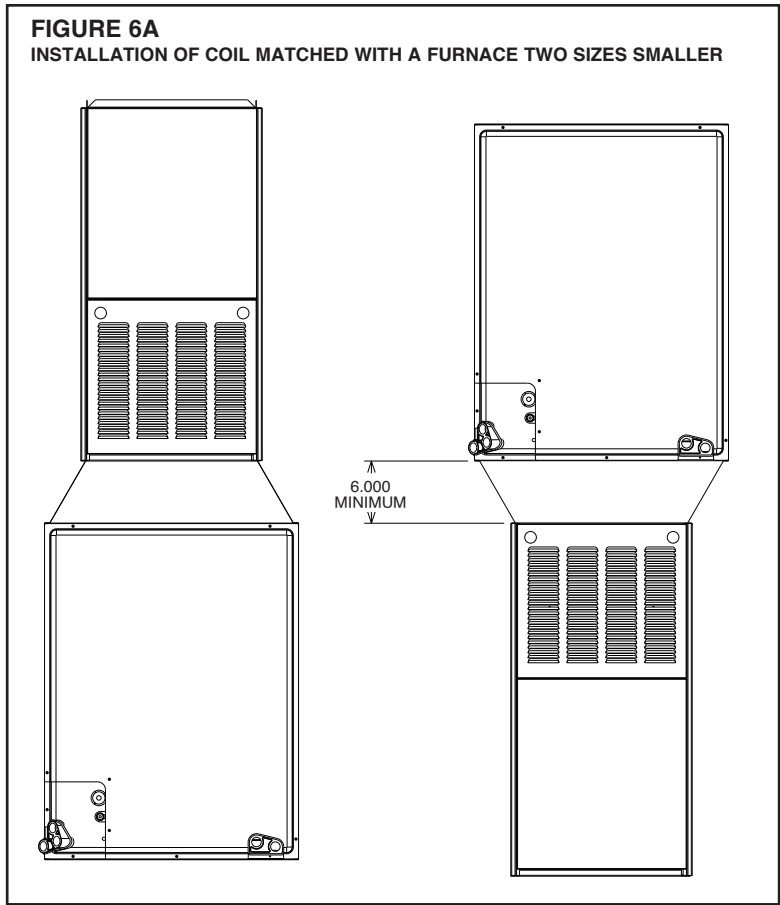
**FIGURE 4**  
**COIL INSTALLATION OPTIONS**



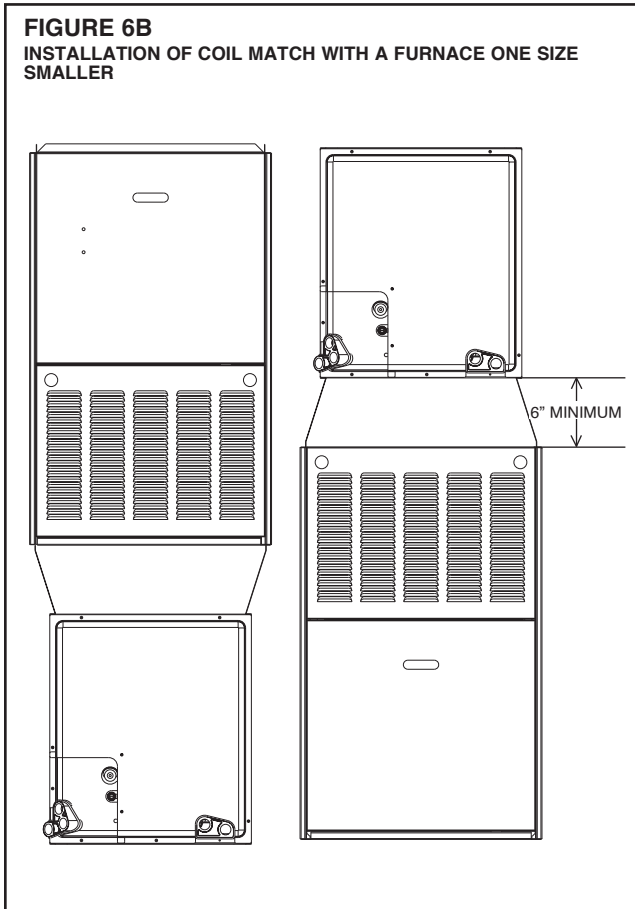
**FIGURE 5**



**FIGURE 6A**  
INSTALLATION OF COIL MATCHED WITH A FURNACE TWO SIZES SMALLER

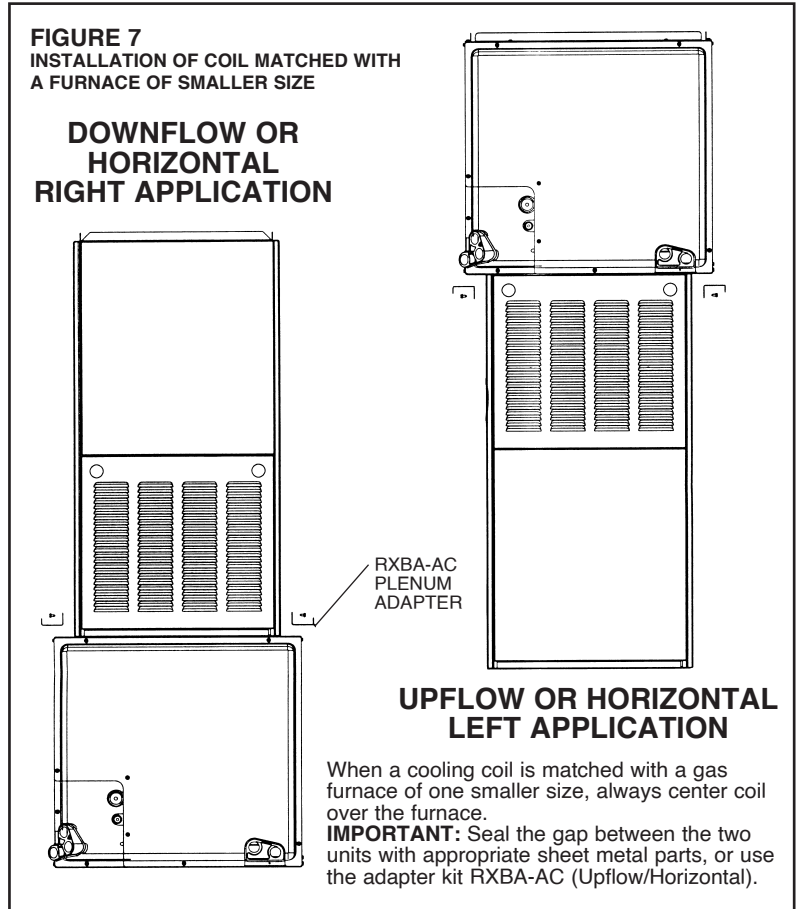


**FIGURE 6B**  
INSTALLATION OF COIL MATCH WITH A FURNACE ONE SIZE SMALLER



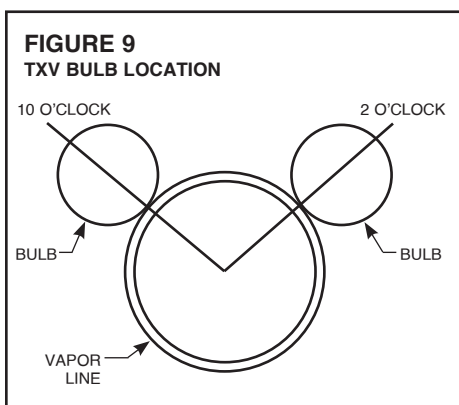
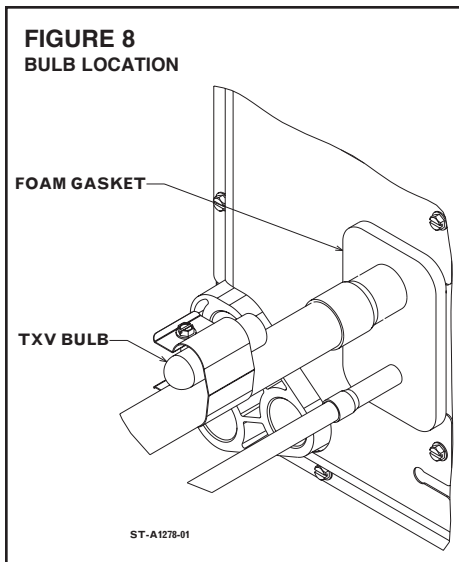
**FIGURE 7**  
INSTALLATION OF COIL MATCHED WITH A FURNACE OF SMALLER SIZE

**DOWNFLOW OR HORIZONTAL RIGHT APPLICATION**



**UPFLOW OR HORIZONTAL LEFT APPLICATION**

When a cooling coil is matched with a gas furnace of one smaller size, always center coil over the furnace.  
**IMPORTANT:** Seal the gap between the two units with appropriate sheet metal parts, or use the adapter kit RXBA-AC (Upflow/Horizontal).



## 3.2 REFRIGERANT CONNECTIONS

Keep the coil connections sealed until refrigerant connections are to be made. See the Installation Instructions for the outdoor unit for details on line sizing, tubing installation, and charging information.

Coil is shipped with a low pressure (5 - 10 PSIG) charge of dry nitrogen. Evacuate the system before charging with refrigerant.

Install refrigerant tubing so that it does not block service access to the front of the unit.

Nitrogen should flow through the refrigerant lines while brazing.

Use a brazing shield to protect the cabinet's paint from being damaged by torch flames.

After the refrigerant connections are made, seal the gap around the connections with pressure sensitive gasket. If necessary, cut the gasket into two pieces for a better seal (See Figure 3.)

## 3.3 TXV SENSING BULB (TXV COILS ONLY)

**IMPORTANT:** DO NOT perform any soldering with the TXV bulb attached to any line.

After soldering operations have been completed, clamp the TXV bulb securely on the suction line at the 10 to 2 o'clock position with the strap provided in the parts bag. (See Figures 7 & 8)

Insulate the TXV sensing bulb and suction line with the provided pressure sensitive insulation (size 4" x 7") and secure with provided wire ties.

**IMPORTANT:** TXV sensing bulb should be located on a horizontal section of copper suction line, just outside of coil box and past the braze joint. The copper sensing bulb must never be placed on any aluminum tube as this will result in galvanic corrosion and eventual failure of the aluminum tube.

## 3.4 ELECTRONIC EXPANSION VALVE (EXV)

EXV equipped coils have a noncommunicating, stand-alone EXV control. One of the biggest advantages of an EXV is the control can intelligently regulate the refrigerant flow based on system demands other than just vapor line temperature and pressure. By the measurement of the suction pressure via the vapor line pressure transducer (factory installed) and the vapor line thermister (field connected to the vapor line, but factory provided) the EXV control calculates the suction superheat at the indoor coil. This calculation permits the EXV control to open or close the electronic expansion valve to maintain a predetermined suction superheat. The electronic valve is equipped with a 4-pole removable external stator, and inlet and outlet Chatleff fittings for optimal serviceability. The EXV also has an internal check valve to provide heat pump compatibility. When operating in heating mode, the air handler control will open the electronic valve completely to permit the check valve to open and maximize reverse refrigerant flow.

## 3.5 EXV VAPOR LINE THERMISTER (EXV COILS ONLY)

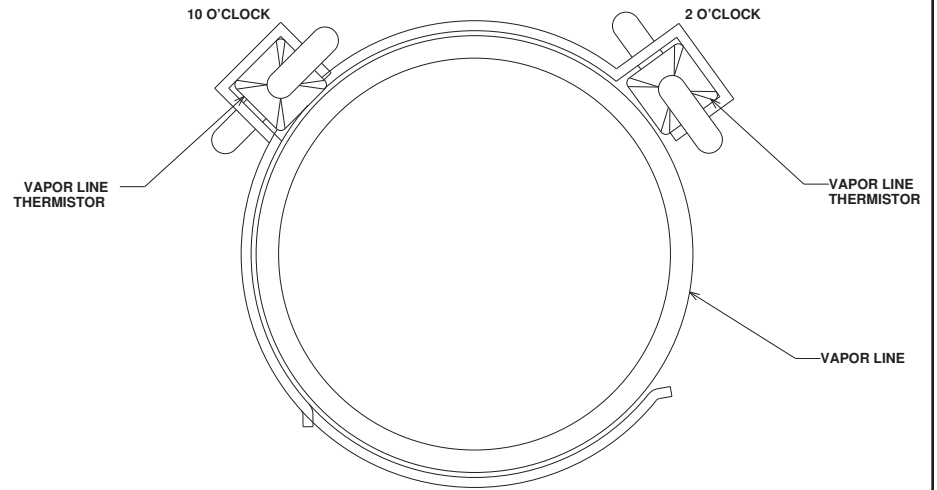
**IMPORTANT:** DO NOT perform any brazing with the vapor line thermister attached to any line. After brazing operations have been completed, clamp the vapor line thermister securely on the vapor line at the 10 to 2 o'clock position (See Figures 10 & 11) with the clip provided on the thermister. Insulate the vapor line thermister and vapor line with the provided pressure sensitive insulation (size 4" x 7") and secure with provided wire ties or simply slide the vapor line insulation over the thermister until it contacts the coil cabinet and secure insulation with a wire tie to keep it in place.

**Make sure to protect the EXV pressure transducer, vapor thermister, copper to aluminum joint, and service valves from overheating by use of wet rag or some type of shielding. Double tip torches are not recommended.**

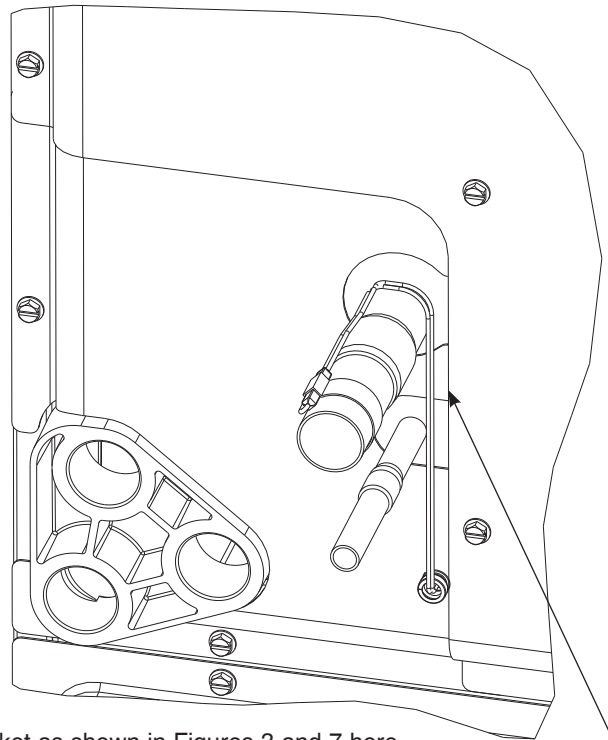
**IMPORTANT:** Vapor line thermister should be located on a horizontal section of vapor line, just outside of coil box and past the braze joint. The copper thermister must never be placed on any aluminum tube as this will result in galvanic corrosion and eventual failure of the aluminum tube.

**IMPORTANT:** Never place the thermister on the heat effected zone near the braze connection, but it should be located within 6" of the indoor unit.

**FIGURE 10**  
**VAPOR LINE THERMISTOR LOCATION**



**FIGURE 11**  
**VAPOR LINE THERMISTOR LOCATION**



Install foam gasket as shown in Figures 3 and 7 here

### 3.6 Factory Programmed Superheat (EXV COILS ONLY)

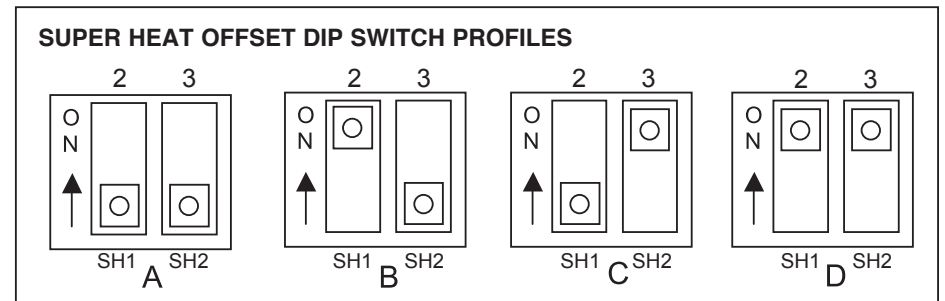
The stand alone EXV control is set at the factory for 10°F superheat. The following DIP switch settings must be set at the time of coil installation, using DIP switches 2 & 3 on the EXV control.

Coil	Outdoor Unit			Superheat (°F)	DIP Switch Settings	
					2	3
(-)CFZ2417SEAN	(-)A18AZ24A			6	ON	OFF
(-)CFZ2421MEAN	(-)A18AZ24A			6	ON	OFF
(-)CFZ2421HEAN	(-)A18AZ24A			6	ON	OFF
(-)CFZ2421HEAA	(-)P18AZ24A			6	ON	OFF
(-)CFZ3621MEAA	(-)A18AZ36A			6	ON	OFF
(-)CFZ3621MEAN	(-)A18AZ36A			8	OFF	ON
(-)CFZ4821SEAA	(-)A18AZ48A			6	ON	OFF
(-)CFZ6021SEAA	(-)A18AZ36A	(-)A18AZ48A	(-)A18AZ60A	6	ON	OFF
	(-)P18AZ36A	(-)P18AZ48A	(-)P18AZ60A	6	ON	OFF
(-)CFZ6024SEAN	(-)A18AZ36A	(-)A18AZ48A	(-)A18AZ60A	6	ON	OFF

### 3.7 SUPERHEAT OFFSET DIP SWITCH SETTINGS (EXV COILS ONLY)

Although the above superheat set point is considered to be the most efficient set point for each coil, installation conditions can drastically effect the measurement of superheat by the EXV control. For this reason the following DIP switch settings have been provided to enable flexibility for various installation conditions.

Superheat Offset Selection Profile	Superheat Setting (°F)
A	10
B	6
C	8
D	12



### 3.8 EXV Step Dip Switch (EXV COILS ONLY)

DIP switch 1 (SS) on the EXV control is factory set for a 500 step EXV (OFF position), but can be switched to the ON position for a 1600 step EXV. This DIP switch must be in the 500 step position only. The DIP switch makes the EXV control forward compatible with a 1600 step EXV for possible future use.

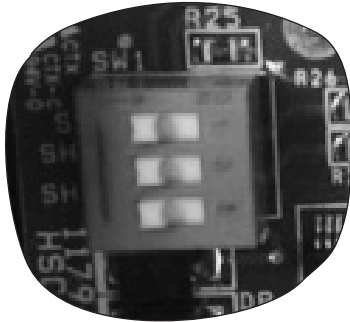
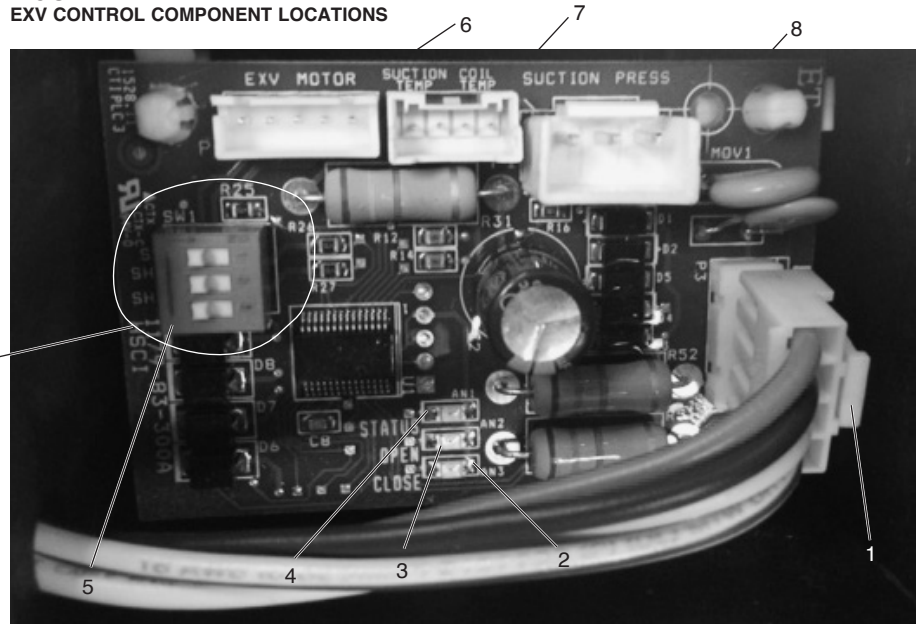
### 3.9 EXV DIAGNOSTICS (EXV COILS ONLY)

There are 2 LEDs (green/yellow) on the EXV control which indicate valve movement. When the green LED is illuminated, the control is moving the valve in the open direction. When the yellow LED is illuminated, the control is moving the valve in the closed direction. When neither LED is illuminated, the valve is not being moved by the control. In addition to the diagnostic lights on the control, it is possible to feel the coil on the EXV pulse when the control is attempting to change the EXV position.

Status LED	Board Fault
1	Only suction temperature valid – suction pressure nor coil temperature are valid
2	No Valid Suction Temperature
3	Valve near open position
4	Suction pressure out of range

### 3.10 EXV CONTROL (EXV COILS ONLY)

**FIGURE 12**  
EXV CONTROL COMPONENT LOCATIONS



**NOTE:** Switches are in “OFF” position from the factory.

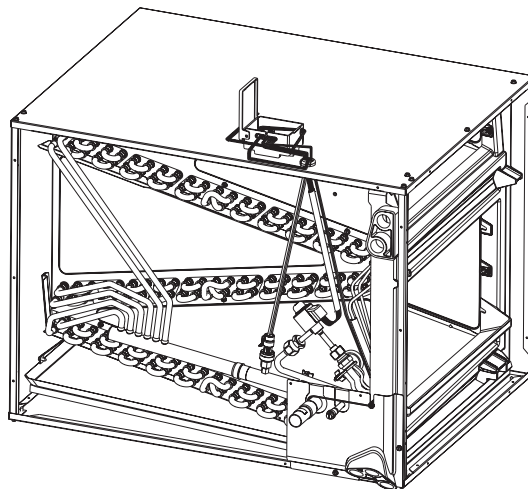
- |   |   |
|---|---|
| 1. Thermostat Connection                                  | 6. Electronic Expansion Valve Connection  |
| 2. Yellow LED (close)                                     | 7. Suction and Coil Thermistor Connection |
| 3. Green LED (open)                                       | 8. Suction Pressure Transducer Connection |
| 4. Red LED (status)                                       |   |
| 5. Dip Switch (EXV steps, 2 & 3 SH adjustment dip switch) |   |

### 3.11 EXV CONTROL OPTIONAL MOUNTING LOCATIONS

The EXV control and housing is factory installed behind the front access panel just above the right drain connections. This location has been tested and approved for long term operation inside the highly humid environment. For servicing the EXV control without removing the coil door or to see the operational lights while the system is in operation, an alternate control and housing location is approved. The mounting location will require the wiring harnesses to be disconnected from the control, the control removed from the housing and the housing mounting screws removed. The wires will need to be routed through the knockout (there is one knockout per side) and then the assembly reassembled externally to the side of the coil case.

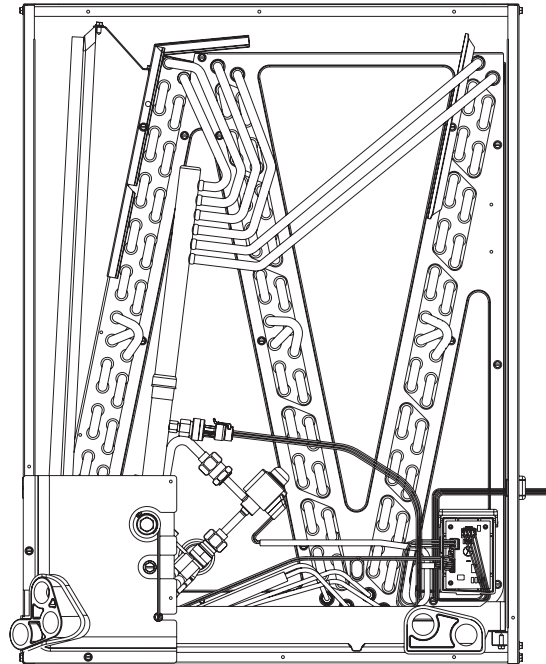
**IMPORTANT:** It is recommended to place aluminum tape over the screw holes in the coil end plate for the factory control mounting position to prevent air bypass.

**FIGURE 13**  
OPTIONAL CONTROL INSTALLATION LOCATION



ST-A1246-01\_S2

**FIGURE 14**  
**FACTORY EXV CONTROL LOCATION**



ST-A1246-01\_S1

**3.12 EXV WIRING (EXV COILS ONLY)**

For proper operation the EXV control requires 24VAC power and staged operation thermostat signals. The following diagram should be used to connect the leads provided with the cased coil to the thermostat wiring. When employed with the EcoNet™ Communicating System attach the leads provided with the coil to the conventional 24VAC thermostat terminals on the EcoNet™ furnace control board.

WIRING DIAGRAM	NOTES	WIRING INFORMATION
	<p><b>NOTES</b></p> <ol style="list-style-type: none"> <li>CONNECTORS SUITABLE FOR USE WITH COPPER CONDUCTORS ONLY.</li> <li>LOW VOLTAGE CIRCUIT TO BE N.E.C. CLASS 2 WITH A CLASS 2 TRANSFORMER 24 VOLT, 50 OR 60 HZ. MIN 18 AWG.</li> <li>TO THERMOSTAT, REFER TO SYSTEM SCHEMATICS OR SCHEMATICS ON FURNACE FOR LOW VOLTAGE CONTROL WIRING.</li> </ol>	<p><b>WIRING INFORMATION</b></p> <p><b>LINE VOLTAGE</b></p> <ul style="list-style-type: none"> <li>-FACTORY STANDARD _____</li> <li>-FACTORY OPTION - - - - -</li> <li>-FIELD INSTALLED - - - - -</li> </ul> <p><b>LOW VOLTAGE</b></p> <ul style="list-style-type: none"> <li>-FACTORY STANDARD _____</li> <li>-FIELD INSTALLED - - - - -</li> <li>REPLACEMENT WIRE - - - - -</li> </ul> <p>-MUST BE THE SAME SIZE AND TYPE OF INSULATION AS ORIGINAL (105C. MIN.)</p> <p><b>WARNING</b></p> <p>-CABINET MUST BE PERMANENTLY GROUNDED AND CONFORM TO I.E.C., N.E.C., C.E.C., NATIONAL WIRING REGULATIONS, AND LOCAL CODES AS APPLICABLE.</p>
<p><b>SCHEMATIC DIAGRAM</b></p>	<p><b>COMPONENT CODES</b></p> <p>CLOSE.....YELLOW LED          COIL TEMP.....COIL INLET THERMISTOR CONNECTION          COMP.....COMPRESSOR          EXV (5 PIN).....ELEC. TX VALVE          ODF.....OUTDOOR FAN CONNECTION          OPEN.....GREEN LED          SH1.....SUPERHEAT OFFSET SWITCH 1          SH2.....SUPERHEAT OFFSET SWITCH 2          SS.....EXV STEP SELECTION (MUST REMAIN OFF)          STATUS.....RED LED          SUCTION PRESSURE.....SUCTION PRESS. TRANSDUCER CONN.          SUCTION TEMP. ....VAPOR LINE THERMISTOR CONN.          TM .....THERMISTOR          RVS.....REVERSING VALVE CONN.</p>	<p><b>WIRE COLOR CODE</b></p> <p>BK.....BLACK G.....GREEN PR.....PURPLE          BR.....BROWN G Y.....GRAY R.....RED          BL.....BLUE O.....ORANGE W.....WHITE          Y.....YELLOW</p> <p><b>ELECTRICAL WIRING DIAGRAM</b></p> <p>NON-COMMUNICATING          STANDALONE          EXV CONTROL W/          PRESSURE TRANSDUCER</p> <p>PART NO.: 90-101897-09 REV: 00</p>

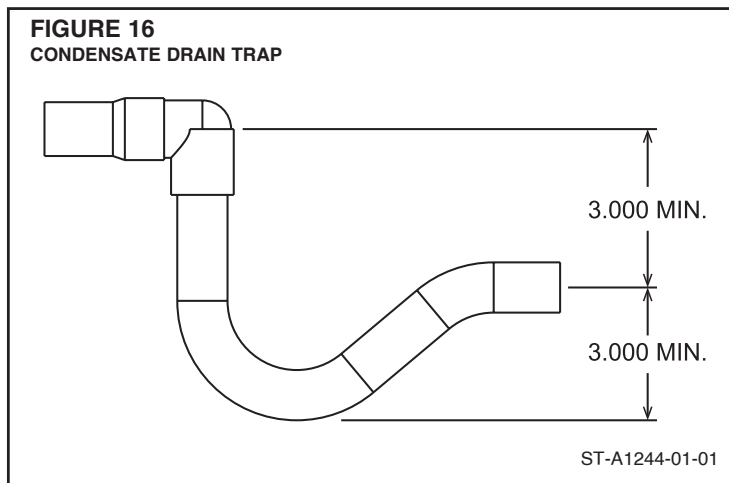
### 3.13 CONDENSATE DRAIN TUBING

Consult local codes or ordinances for specific requirements.

**IMPORTANT:** When making drain fitting connections to the drain pan, use a thin layer of Teflon paste, silicone or Teflon tape and install hand tight.

**IMPORTANT:** When making drain fitting connections to drain pan, do not overtighten. Overtightening fittings can split pipe connections on the drain pan.

- Install drain lines so they do not block service access to front of the unit. Minimum clearance of 24 inches is required for filter, coil or blower removal and service access.
- Make sure unit is level or pitched slightly toward primary drain connection so that water will drain completely from the pan. (See Figure 16.)
- Do not reduce drain line size less than connection size provided on condensate drain pan.
- All drain lines must be pitched downward away from the unit a minimum of 1/8" per foot of line to ensure proper drainage.
- Do not connect condensate drain line to a closed or open sewer pipe. Run condensate to an open drain or outdoors.
- The drain line should be insulated where necessary to prevent sweating and damage due to condensate forming on the outside surface of the line.
- Make provisions for disconnecting and cleaning of the primary drain line should it become necessary. Install a 3 in. trap in the primary drain line as close to the unit as possible. Make sure that the top of the trap is below connection to the drain pan to allow complete drainage of pan (See Figure 15).
- Auxiliary drain line should be run to a place where it will be noticeable if it becomes operational. Occupant should be warned that a problem exists if water should begin running from the auxiliary drain line.
- Plug the unused drain connection with the plugs provided in the parts bag, using a thin layer of teflon paste, silicone or teflon tape to form a water tight seal.
- Test condensate drain pan and drain line after installation is complete. Pour water into drain pan, enough to fill drain trap and line. Check to make sure drain pan is draining completely, no leaks are found in drain line fittings, and water is draining from the termination of the primary drain line.



### CAUTION

It is recommended that an auxiliary/secondary drain pan be installed under units containing evaporator coils that are located in any area of a structure where damage to the building or building contents may occur as a result of an overflow of the coil drain pan or a stoppage in the primary condensate drain piping.



### 3.14 DUCT FLANGES

Field-installed duct flanges (4 pieces) are shipped with units. Install duct flanges as needed on top or bottom of the coil casing. (See Figure 17.)

### 3.15 COIL END SHIELDS

All uncased replacement coils come equipped from the factory with sheet metal shields at the front and rear of the coil. The purpose of these shields is to isolate the aluminum tubing from copper residue left on the foil insulation by the original copper tube coil. Copper residue or copper oxide in contact with the aluminum tubing in the presence of moisture will result in galvanic corrosion and leaks in the aluminum tube at the contact point. The shields must be in place on the coil when replacing a copper tube coil to prevent the galvanic corrosion.

#### **WARNING**

**These instructions are intended as an aid to qualified licensed service personnel for proper installation, adjustment and operation of this unit. Read these instructions thoroughly before attempting installation or operation. Failure to follow these instructions may result in improper installation, adjustment, service or maintenance possibly resulting in fire, electrical shock, property damage, personal injury or death.**

## 4.0 MAINTENANCE

For continuing high performance and to minimize possible equipment failure, it is essential that annual maintenance be performed on this equipment. Consult your local dealer as to the availability of a maintenance contract.

### 4.1 AIR FILTER

Check the system filter every ninety days or as often as found to be necessary and if obstructed, clean or replace at once.

**IMPORTANT:** Do not operate the system without a filter in place.

### 4.2 INDOOR COIL - DRAIN PAN - DRAIN LINE

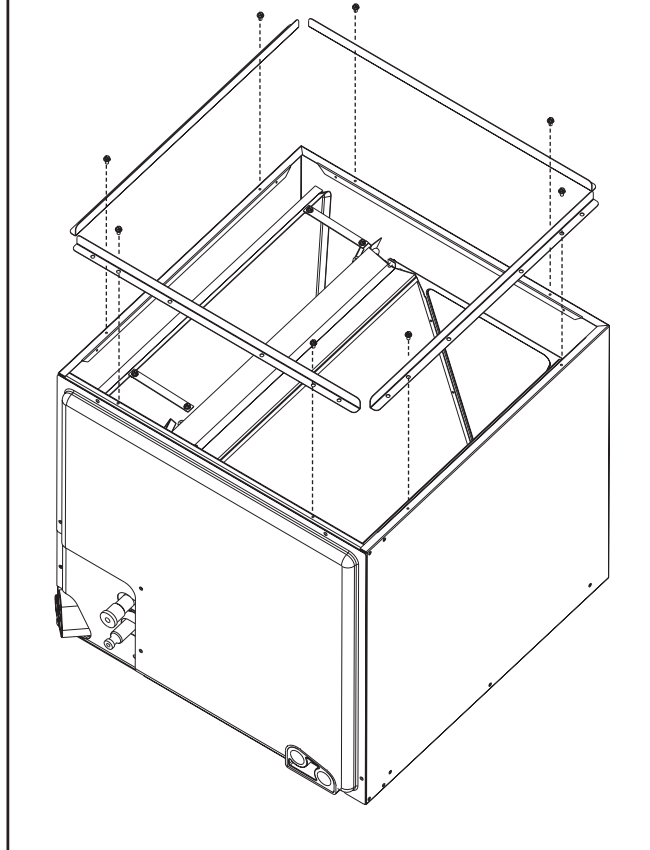
Inspect the indoor coil, drain pan, and drain line once each year for cleanliness and clean as necessary. Be sure to check the finned surface on the return side of the coil. It may be necessary to remove the air-filter and use a mirror and flashlight to view the return side of the coil.

**Note:** A proper filter is the best defense against a dirty coil. Regardless of the filter choice, proper air flow and velocity also play a crucial role in how effective a filter will be. Most filters will lose their effectiveness when face velocities exceed 300 - 400 feet per minute. Excessive air velocity can allow particles to pass right through the media. Additionally, loaded or restrictive filters may lose their shape in higher air velocity applications and allow unfiltered air to bypass the filter altogether around the sides.

**IMPORTANT:** Coil and Drainpan Cleaning Method

Clean the finned surface of the indoor coil by rinsing the coil from both sides with clean warm water and/or with a vacuum with a soft brush attachment to remove accumulated contaminants and lint. It is important not to allow the tool to damage or bend the fins. Many chemical cleaners will attack the aluminum tubes which can cause refrigerant leaks. Therefore, use only clean warm water for cleaning aluminum tube evaporator coils. Do not use caustic household drain cleaners or bleach in the condensate pan or near the indoor coil as they will damage the aluminum fins and tubes.

**FIGURE 17**  
**FIELD-INSTALLED DUCT FLANGES**



## **5.0 ACCESSORIES**

### **5.1 PLENUM ADAPTER ACCESSORY RXBA-AE**

This plenum adapter accessory is for use with the 24-1/2" wide cased indoor cooling and heat pump coils. This allows a 24-1/2 wide cased coil to be installed on a 28" wide oil furnace. This is a field-installed accessory only.

### **RXBA-AC**

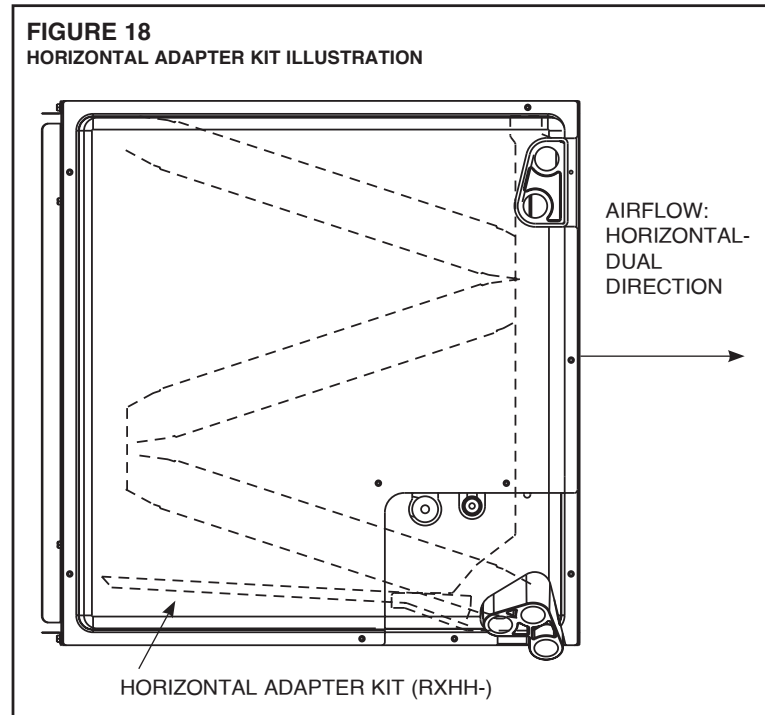
This plenum adapter accessory is for installation on cased indoor cooling and heat pump coils. This allows a nominal size cased coil to be installed on the next smaller size gas or oil furnace. **NOTE: This accessory is for installation on coil casings to fit gas or oil furnaces only - this accessory must not be used on electric furnaces or heat pump air handlers.** Consult the installation instructions packaged with the accessory for proper installation.

**TABLE 3**  
**HORIZONTAL ADAPTER KIT**

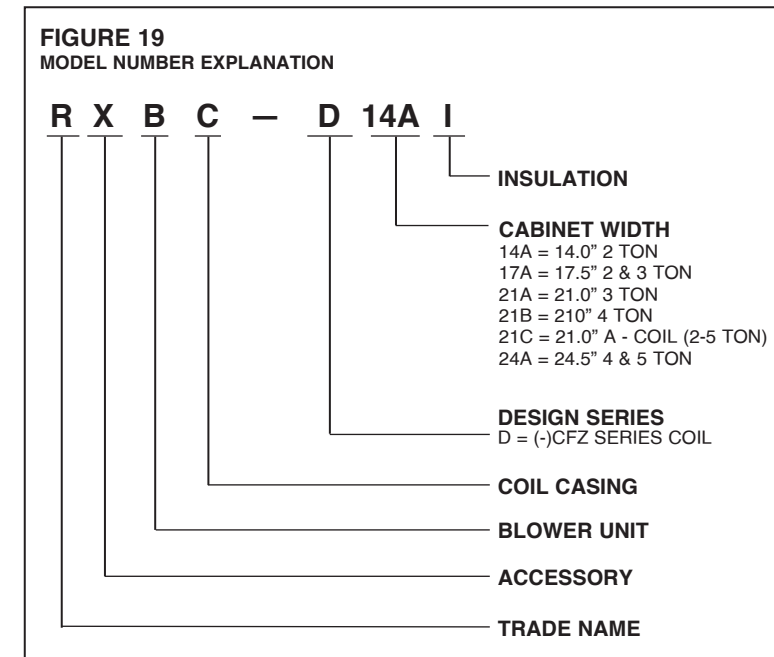
Uncased Coil Model	Horizontal Adapter Kit Model No.
(-)CFZ2414STAAVU	RXHH-A01
(-)CFZ2417STANVU	RXHH-A02
(-)CFZ2417SEANVU	RXHH-A02
(-)CFZ2517STANVU	RXHH-A02
(-)CFZ2417MTANVU	RXHH-A03
(-)CFZ2421MTANVU	RXHH-A03
(-)CFZ2421MEANVU	RXHH-A03
(-)CFZ2421HEANVU	RXHH-A04
(-)CFZ2421HEAAVU	RXHH-A06
(-)CFZ3617STANVU	RXHH-A03
(-)CFZ3717STANVU	RXHH-A03
(-)CFZ3621STANVU	RXHH-A03
(-)CFZ3621MTANVU	RXHH-A04
(-)CFZ3621MEANVU	RXHH-A04
(-)CFZ3621MTAAVU	RXHH-A06
(-)CFZ3621MEAAVU	RXHH-A06
(-)CFZ3624MTANVU	RXHH-A04
(-)CFZ4821STANVU	RXHH-A04
(-)CFZ4921STANVU	RXHH-A04
(-)CFZ4821STAAVU	RXHH-A06
(-)CFZ4821SEAAVU	RXHH-A06
(-)CFZ4824STANVU	RXHH-A04
(-)CFZ4824MTANVU	RXHH-A05
(-)CFZ6021STAAVU	RXHH-A06
(-)CFZ6021SEAAVU	RXHH-A06
(-)CFZ6024STANVU	RXHH-A05
(-)CFZ6024SEANVU	RXHH-A05
(-)CFZ6124STANVU	RXHH-A05

**5.2 HORIZONTAL ADAPTER KIT RXHH- (See Figure 18 & Table 3)**

This horizontal adapter kit is used to convert an upflow or downflow coil for a horizontal application. See Table 3 to order the proper horizontal adapter kit.



**5.3 EMPTY INDOOR COIL CASING RXBC - (See Figure 19 & Table 4)**



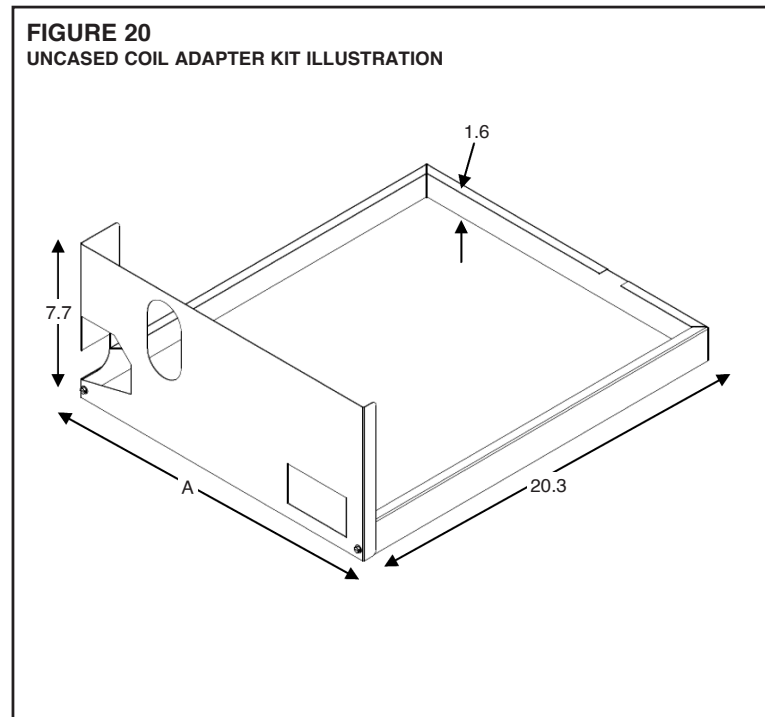
**TABLE 4**

**UNIT DIMENSIONS & WEIGHTS – RXBC- INDOOR COIL CASINGS**

Model Number	Width (in) [mm]	Height (in) [mm]	Depth (in) [mm]	Unit Weight		Supply Air / Return Air Openings	
				Weight (lbs) [kg]	Ship Wt (lbs) [kg]	Width (in) [mm]	Depth (in) [mm]
RXBC-D17AI	(17 1/2) [445]	(20) [508]	(21 5/8) [549]	(18) [8]	(23) [10]	(16 1/2) [mm]	(19 31/32) [507]
RXBC-D21AI	(21) [533]	(20) [508]		(20) [9]	(26) [12]	(20) [508]	
RXBC-D21BI	(21) [533]	(28) [711]		(28) [13]	(34) [15]		
RXBC-D21CI	(21) [533]	(34 1/2) [876]		(33) [14]	(39) [17]		
RXBC-D24AI	(24 1/2) [622]	(32 1/2) [826]		(34) [15]	(44) [20]	(23 1/2) [597]	

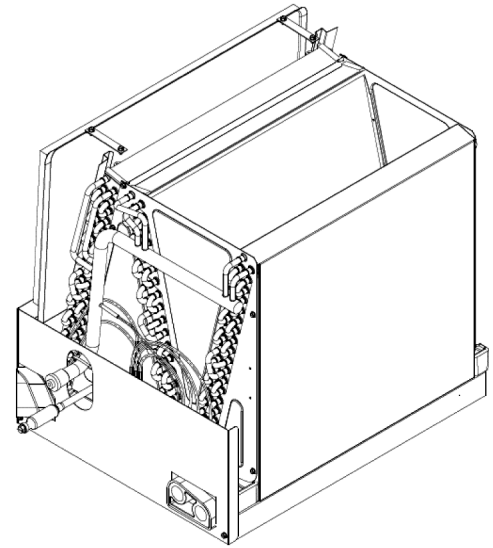
**5.4 UNCASSED COIL ADAPTER KIT  
RXBA- (See Figures 20 & 21)**

This kit is used to adapt an uncased coil to a furnace or ductwork. See Table 5 for model numbers. Each kit contains a quantity of 20 adapters.



**TABLE 5****UNCASED COIL ADAPTER KIT**

Uncased Coil Adapter Model Number RXBA	A Width In.	Uncased Coil Model (-)CFZ
B14x20	13.1	**14
B17x20	16.6	**17
B21x20	20.1	**21
B24x20	23.6	**24

**FIGURE 21**  
**UNCASED COIL ADAPTER KIT ASSEMBLED**

**NOTE:** Sliding the coil into the coil rail before attaching coil rack front.

**5.5 R-22 TXV CONVERSION KITS**

**To be used to convert R-410A coil to operate with R-22**

**TABLE 6**  
**FURNACE COIL CROSS REFERENCE CHART**

ORIGINAL COIL	RECOMMENDED ALUMINUM TUBE REPLACEMENT COIL	R-22 TXV CONVERSION KIT MODEL NO.
(-)CFA-**2414	(-)CFZ2414STA	RXCT-HBA
(-)CFA-**2417	(-)CFZ2417STA, (-)CFZ2517STA	RXCT-HBA
(-)CFA-**3617	(-)CFZ3617STA, (-)CFZ3717STA, (-)CFZ2417MTA, (-)CFZ2417HTA, (-)CFZ3621H	RXCT-HBB
(-)CFA-**3621	(-)CFZ3621STA, (-)CFZ2421MTA, (-)CFZ2421HTA, (-)CFZ3621H	RXCT-HBB
(-)CFA-**4821	(-)CFZ4821STA, (-)CFZ4921STA, (-)CFZ3621MTA, (-)CFZ4821M	RXCT-HBC
(-)CFA-**4824	(-)CFZ4824STA, (-)CFZ3624MTA, (-)CFZ4821M	RXCT-HBC
(-)CFA-**6024	(-)CFZ6024STA, (-)CFZ6124STA, (-)CFZ6024HTA, (-)CF4824HTA, (-)CFZ3624HTA, (-)CFZ6021S	RXCT-HBD

\*\*= AU, HM, OR HU





