

**⚠ WARNING:**

RECOGNIZE THIS SYMBOL AS AN INDICATION OF IMPORTANT SAFETY INFORMATION

**⚠ WARNING**

THESE INSTRUCTIONS ARE INTENDED AS AN AID TO QUALIFIED, LICENSED SERVICE PERSONNEL FOR PROPER INSTALLATION, ADJUSTMENT, AND OPERATION OF THIS UNIT. READ THESE INSTRUCTIONS THOROUGHLY BEFORE ATTEMPTING INSTALLATION OR OPERATION. FAILURE TO FOLLOW THESE INSTRUCTIONS MAY RESULT IN IMPROPER INSTALLATION, ADJUSTMENT, SERVICE, OR MAINTENANCE POSSIBLY RESULTING IN FIRE, ELECTRICAL SHOCK, PROPERTY DAMAGE, PERSONAL INJURY, OR DEATH.

Do not destroy this manual. Please read carefully and keep in a safe place for future reference by a serviceman.

[ ] indicates metric conversions.

92-104921-25-04( / )

Printed in the USA

# VARIABLE SPEED R-410A HEAT PUMP/ AIR CONDITIONING OUTDOOR UNITS



## INSTALLATION INSTRUCTIONS

**(-)A15AZ(-)P16AZ/(-)A16AZ  
(15/16 SEER2) EQUIPPED WITH  
ECONET™ COMMUNICATIONS**

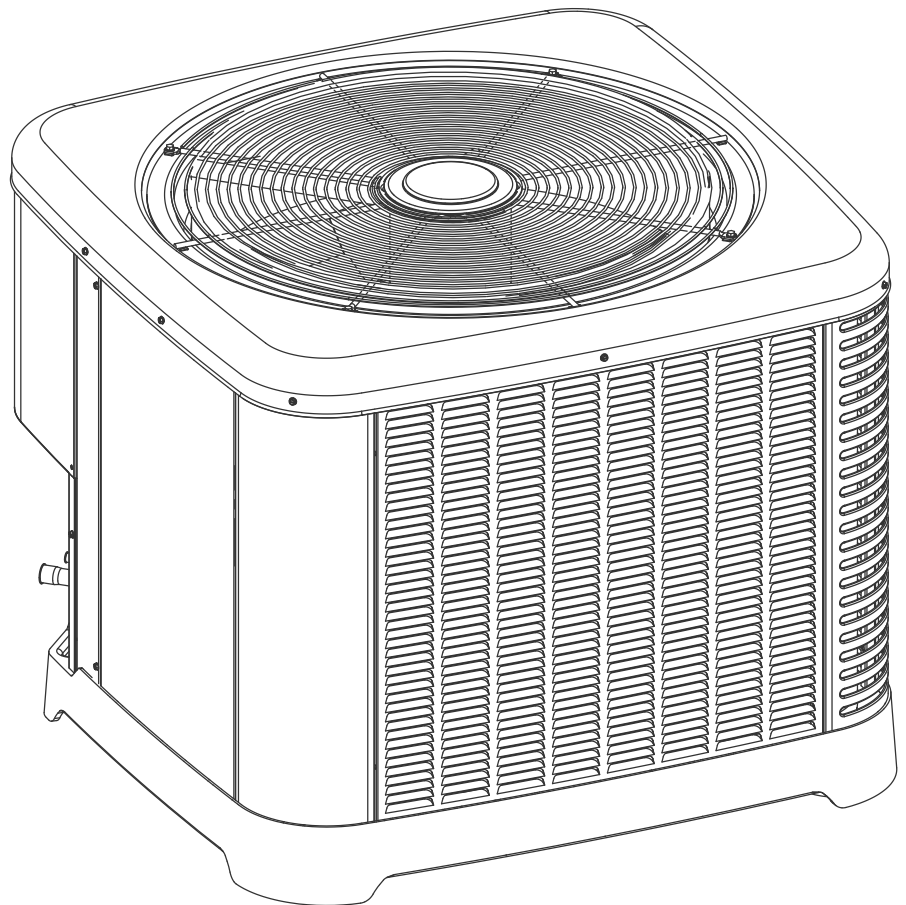

ISO 9001:2015



# CONTENTS

<b>1.0 IMPORTANT SAFETY INFORMATION</b> .....	<b>3</b>
<b>2.0 GENERAL INFORMATION</b> .....	<b>4</b>
2.1 Introduction .....	4
2.2 Agency Performance Audit Testing Notice .....	4
2.3 Importance of Quality Installation .....	4
2.4 System Sizing and Selection .....	4
2.5 Importance of Proper Indoor/Outdoor Match-Ups .....	5
2.6 Checking Product Received .....	5
2.7 Compressor Break-In Notice .....	5
<b>2.0 GENERAL INFORMATION</b> .....	<b>5</b>
<b>3.0 UNIT SPECIFICATIONS</b> .....	<b>6</b>
3.1 Model Number Nomenclature and Available Models .....	6
3.2 Electrical and Physical Data .....	7
<b>4.0 INSTALLATION</b> .....	<b>8</b>
4.1 Tools and Refrigerant .....	8
4.1.1 Tools Required for Installing and Servicing R-410A Models .....	8
4.1.2 Specifications of R-410A .....	8
4.1.3 Quick-Reference Guide for R-410A .....	8
4.2 Choosing a Location .....	9
4.2.1 Allowable Clearances .....	9
4.2.2 Operational Issues Related to Unit Location .....	9
4.2.3 Corrosive Environment .....	10
4.2.4 Customer Satisfaction Issues .....	10
4.3 Unit Mounting .....	10
4.3.1 Unit Mounting Methods .....	10
4.3.2 High Wind and Seismic Tie-Down Methods .....	10
4.2 Choosing a Location (cont.) .....	10
4.3.3 Elevating Unit .....	11
4.4.1 Replacing Existing Systems .....	12
4.4.2 Line Set Application Considerations .....	12
4.4.2.1 Oil Return to Compressor .....	12
4.4.2.2 Refrigerant Migration During Off Cycle .....	12
4.4.2.3 Maximum Liquid Pressure Drop .....	12
4.4.2.4 Liquid Line Refrigerant Flashing .....	12
4.4 Refrigerant Line Set Selection .....	12
4.4.2.5 Oil Level Adjustment for Long Line Set Applications .....	13
4.4.2.6 Capacity Losses .....	13
4.4.3 Line Set Length and Fitting Losses .....	13
4.4.4 Liquid Line Selection .....	14
4.4.5 Vapor Line Selection .....	14
4.5 Line Set Installation .....	17
4.5.1 Important Tubing Installation Practices .....	17
4.5.2 Relative Location of Indoor and Outdoor Units .....	18
4.5.2.1 Outdoor Unit Level or Near Level to Indoor Coil Line Set .....	18
4.5.2.2 Outdoor Unit Below Indoor Coil (Long Line Set Applications) .....	19
4.5.2.3 Outdoor Unit Above Indoor Coil .....	20
4.5.3 Tubing Connections .....	21
4.6 Initial Leak Testing .....	22
4.7 Evacuation .....	22
4.8 Final Leak Testing .....	23
4.9 Control Wiring .....	23
4.9.1 EcoNet™ Communications .....	23
4.9.2 EcoNet™ Control Center Installation .....	23
4.9.3 EcoNet™ Communication Wiring Connections .....	23
4.9.4 Conventional 24VAC Thermostat Control Wiring Connections .....	24
4.9.5 For Installations with Only 2 Thermostat Wires .....	25
4.9 Control Wiring (cont.) .....	26
4.10 Power Wiring .....	27
4.11 Grounding .....	27
<b>5.0 SYSTEM START-UP AND REFRIGERANT CHARGING</b> .....	<b>28</b>
5.1 System Start-Up Overview .....	28
5.2 Initial Power-Up .....	28
and EcoNet™ Communication Verification .....	28
5.3 EcoNet™ Control Center Set-Up .....	28
5.4 Initial System .....	27
Start-Up .....	27
5.5 Entering Charge Mode Using EcoNet™ Control Center Service Menu .....	29
5.6 Entering Charge Mode When Using a Universal Outdoor Control .....	29
5.7 Indoor Air-Flow Verification .....	30
5.8 Refrigerant Charging .....	30
5.8.1 Measurement Device Set-Up .....	31
5.8.2 Preliminary Charging by Weight .....	31
5.8.3 Preliminary Charging by Pressures (Optional) .....	31
5.8.4 Final Charging by Liquid Subcooling .....	30
5.8.5 R-410A Temperature Pressure Chart .....	30
5.9 Completing Installation .....	30
<b>6.0 NORMAL SEQUENCE OF OPERATION</b> .....	<b>33</b>
6.1 Cooling Mode .....	33
6.2 On-Demand Cooling Dehumidification .....	33
6.3 Low Ambient Cooling Mode .....	33
6.4 Supplemental Electric Heat in Heating Mode .....	33
6.5 Dual Fuel Applications – Heating Mode .....	34
6.6 Demand Defrost .....	34
6.7 Sequence of Operation for Conventional 2-Stage 24VAC Thermostat Controls .....	35
<b>7.0 COMPONENTS &amp; CONTROLS</b> .....	<b>36</b>
7.1 EcoNet™ Universal Outdoor Control (UODC) .....	36
7.1.1 Board Features and Connections .....	36
7.1.2 Factory Superheat Setting .....	36
7.2 Power Inverter Compressor Control .....	37
<b>8.0 ACTIVE SYSTEM PROTECTION FEATURES</b> .....	<b>38</b>
8.1 Minimum Run Timer .....	38
8.2 Oil Return Cycle .....	38
8.3 High Discharge Temperature .....	38
8.4 High Discharge Pressure .....	38
8.5 Low Suction Pressure/ .....	38
Loss of Charge .....	38
8.6 Compressor Shut-Down Sequence for High or Low Refrigerant Pressure Fault .....	39
8.7 Overcurrent and Current Imbalance .....	39
8.8 Compressor Operation Outside Envelope .....	39
8.9 Over and Under Voltage .....	39
8.10 Inverter Over Temperature .....	39
8.11 Controls and Communication Malfunction .....	39
8.12 Sensor Failure Default Operation .....	40
8.13 Exiting Active Protection Lock-Out Mode .....	40
<b>9.0 DIAGNOSTICS &amp; TROUBLESHOOTING</b> .....	<b>41</b>
9.1 Checking Transducers & Temperature Sensors .....	43
9.2 General Troubleshooting Guide .....	45
9.3 Service Analyzer Charts .....	46
9.4 Troubleshooting Tips .....	51
<b>10.0 OUTDOOR UNIT MAINTENANCE</b> .....	<b>52</b>
10.1 Outdoor Coil Cleaning .....	52
10.2 Cabinet Cleaning and Care .....	52
10.3 Motor Lubrication .....	52
10.4 Replacement Parts .....	52
<b>11.0 WIRING DIAGRAM</b> .....	<b>53</b>
<b>12.0 APPENDIX</b> .....	<b>55</b>
12.1 Agency Performance Audit Test Instructions .....	56

# 1.0 IMPORTANT SAFETY INFORMATION

## ⚠️ WARNINGS:

- These instructions are intended as an aid to qualified, licensed service personnel for proper installation, adjustment, and operation of this unit. Read these instructions thoroughly before attempting installation or operation. **Failure to follow these instructions may result in improper installation, adjustment, service, or maintenance possibly resulting in fire, electrical shock, property damage, personal injury, or death.**
- **The unit must be permanently grounded. Failure to do so can cause electrical shock resulting in severe personal injury or death.**
- **Turn off electric power at the fuse box or service panel before making any electrical connections.**
- **Complete the ground connection before making line voltage connections. Failure to do so can result in electrical shock, severe personal injury, or death.**
- **Disconnect all power to unit before starting maintenance. Failure to do so can cause electrical shock resulting in severe personal injury or death.**
- **Never assume the unit is properly wired and/or grounded. Always test the unit cabinet with a noncontact voltage detector available at most electrical supply houses or home centers before removing access panels or coming into contact with the unit cabinet.**
- **DO NOT use oxygen to purge lines or pressurize system for leak test. Oxygen reacts violently with oil, which can cause an explosion resulting in severe personal injury or death.**
- The top of the scroll compressor shell is hot. Touching the compressor top may result in serious personal injury.
- The manufacturer's warranty does not cover any damage or defect to the unit caused by the attachment or use of any components, accessories, or devices (other than those authorized by the manufacturer) into, onto, or in conjunction with the heat pump. **You should be aware that the use of unauthorized components, accessories, or devices may adversely affect the operation of the heat pump and may also endanger life and property.** The manufacturer disclaims any responsibility for such loss or injury resulting from the use of such unauthorized components, accessories, or devices.
- This product is not approved for installation at 6561 feet [2000 meters] above sea level or higher. Installation at higher altitudes may result in control and unit failures due to electrical arc tracking between electrical components on the inverter drive control board. Possibly resulting in fire, electrical shock, property damage, personal injury, or death.

## ⚠️ CAUTIONS:

- R-410A systems operate at approximately 60% higher pressures (1.6 times) than R-22 systems. Do not use R-22 service equipment or components on R-410A equipment. Use appropriate care when using this refrigerant. Failure to exercise care may result in equipment damage or personal injury.
- Only match this outdoor unit with a matched indoor coil or air handler approved for use with this outdoor unit per the unit manufacturer's specification sheet. The use of unmatched coils or air handler will likely result in a charge imbalance between the cooling and heating modes which can cause unsatisfactory operation including a high-pressure switch lockout condition.
- Only use indoor coils approved for use on R-410A systems. An R-22 coil will have a TXV or fixed expansion device that is not designed to operate properly in an R-410A system and will result in serious operational issues. The R-22 coil could also contain a significant amount of mineral oil which is incompatible with the POE oil used in R-410A systems and could result in reliability issues with the compressor and expansion devices.
- When the indoor coil or air handler is installed over a finished ceiling and/or living area, it is required that an auxiliary overflow pan be constructed and installed under the entire indoor unit. Failure to do so can result in property damage.
- **UNIT MAY START SUDDENLY AND WITHOUT WARNING.** The blue cooling status LED shall blink (1 second ON, 1 second OFF) if waiting for the short cycle timer (LOCKTIMER) to expire, otherwise it shall blink the first digit of the capacity percentage requested (for example, blink 7 times for 70% capacity). At 100% capacity the LED shall be solid on. The orange heating status LED shall blink (1 second ON, 1 second OFF) if waiting for the short cycle timer (LOCKTIMER) to expire, otherwise it shall blink the first digit of the capacity percentage requested (for example, blink 7 times for 70% capacity). At 100% capacity the LED shall be solid on.

# 2.0 GENERAL INFORMATION

## **⚠WARNING:**

Improper installation, or installation not made in accordance with these instructions, can result in unsatisfactory operation and/or dangerous conditions and can cause the related warranty not to apply.

## 2.1 Introduction

The (-)A15AZ/(-)P16AZ/(-)A16AZ series heat pumps and condensing units are specifically designed to operate with matching communicating EcoNet™ enabled air-handlers, gas furnaces, and Control Center. A conventional 24VAC 2-stage thermostat can be used, but many features and benefits are lost.

This installation instruction manual contains complete instructions for installation and setup using the EcoNet™ or conventional 24VAC 2-stage controls. Please refer to the manufacturer's specification sheets for complete performance data, thermostat, and accessory listings.

The information contained in this manual has been prepared to assist in the proper installation, operation, and maintenance of the air conditioning system.

Read this manual and any instructions packaged with separate equipment required to make up the system prior to installation. Homeowner should retain this manual for future reference.

## 2.2 Agency Performance Audit Testing Notice

**For purposes of verifying or testing efficiency ratings, the test procedure in Title 10 APPENDIX M to Subpart B of Part 430 (Uniform Test Method for Measuring the Energy Consumption of Central Air Conditioners and Heat Pumps) and the clarifying provisions provided in the AHRI Operations Manual 210/240 that were applicable at the date of manufacture should be used for test set up and performance.**

Should this unit be selected for performance audit testing, follow the instructions included in the Appendix (Section 12.1) of this manual.

## 2.3 Importance of Quality Installation

A quality installation is critical to assure safety, reliability, comfort, and customer satisfaction. Strict adherence to applicable codes, the information in this installation manual, the outdoor unit installation manual, and the thermostat installation manual are key to a quality installation. Read the entire instruction manuals before starting the installation.

**IMPORTANT:** This product has been designed and manufactured to meet certified AHRI capacity and efficiency ratings with the appropriate outdoor units. However, proper refrigerant charge, proper airflow, and refrigerant line sizing are critical to achieve optimum capacity and efficiency and to assure reliable operation. Installation of this product should follow the manufacturer's refrigerant charging and airflow instructions located in this installation manual and the charging chart label affixed to the outdoor unit. Failure to confirm proper charge and airflow may reduce energy efficiency and shorten equipment life.

The equipment has been evaluated in accordance with the Code of Federal Regulations, Chapter XX, Part 3280.

Install the unit in accordance with applicable national, state, and local codes. Latest editions are available from: "National Fire Protection Association, Inc., Batterymarch Park, Quincy, MA 02269." These publications are:

- ANSI/NFPA No. 70-(Latest Edition) National Electrical Code.
- NFPA90A Installation of Air Conditioning and Ventilating Systems.
- NFPA90B Installation of warm air heating and air conditioning systems.

Install the unit in such a way as to allow necessary access to the coil/filter rack and blower/control compartment.

## 2.4 System Sizing and Selection

Before specifying any heat pump equipment, a survey of the structure and heat loss and heat gain calculations must be made. A heat loss calculation involves identifying all surfaces and openings that lose heat to the surrounding air in the heating mode and quantifying that heat loss. A heat gain calculation makes similar measurements and determines the amount of heat required to be removed in the cooling mode. A heat gain calculation also calculates the extra heat load caused by sunlight and by humidity removal. These factors must be considered before selecting a heat pump system to provide year-round comfort. The Air Conditioning Contractors of America (ACCA)



# 2.0 GENERAL INFORMATION

Manual J method of load calculation is one recognized procedure for determining the heating and cooling load.

After the proper equipment combination has been selected, satisfying both sensible and latent requirements, the system must be properly installed. Only then can the system provide the comfort it was designed to provide.

There are several factors that installers must consider.

- Outdoor unit location
- Indoor unit blower speed and airflow
- Proper equipment evacuation
- Supply and return air duct design and sizing
- Refrigerant charge
- System air balancing
- Diffuser and return air grille location and sizing

**IMPORTANT:** Excessive use of elbows in the refrigerant line set can produce excessive pressure drop. Follow industry best practices for installation. Installation and commissioning of this equipment is to be performed by trained and qualified HVAC professionals. For technical assistance, contact your Distributor Service Coordinator.

## 2.5 Importance of Proper Indoor/Outdoor Match-Ups

To assure many years of reliable operation and optimum customer comfort and to assure the outdoor unit warranty remains valid, an air-handler model or indoor coil/furnace combination should be selected that is properly matched to the outdoor unit. This is especially critical for heat pump systems to assure proper refrigerant charge balance between the cooling and heating modes. The recommended approach is to select an air-handler or indoor coil and gas furnace that has an AHRI match with the outdoor unit. Refer to the AHRI directory at [www.ahridirectory.org](http://www.ahridirectory.org) to confirm the air-handler and outdoor unit are a certified combination in the AHRI Directory.

## 2.6 Checking Product Received

Upon receiving unit, inspect it for any shipping damage. Claims for damage, either apparent or concealed, should be filed immediately with the

shipping company. Check model number, electrical characteristics, and accessories to determine if they are correct. Check system components (indoor coil, outdoor unit, air handler/furnace, etc.) to make sure they are properly matched.

## 2.7 Compressor Break-In Notice

Prior to agency testing, system must be operated for 20 hours at 115°F [46.1°C] outdoor ambient temperature with 80°F [26.7°C] dry bulb 75°F [23.9°C] wet bulb indoor ambient temperature to break the compressor in.

# 3.0 UNIT SPECIFICATIONS

## 3.1 Model Number Nomenclature and Available Models

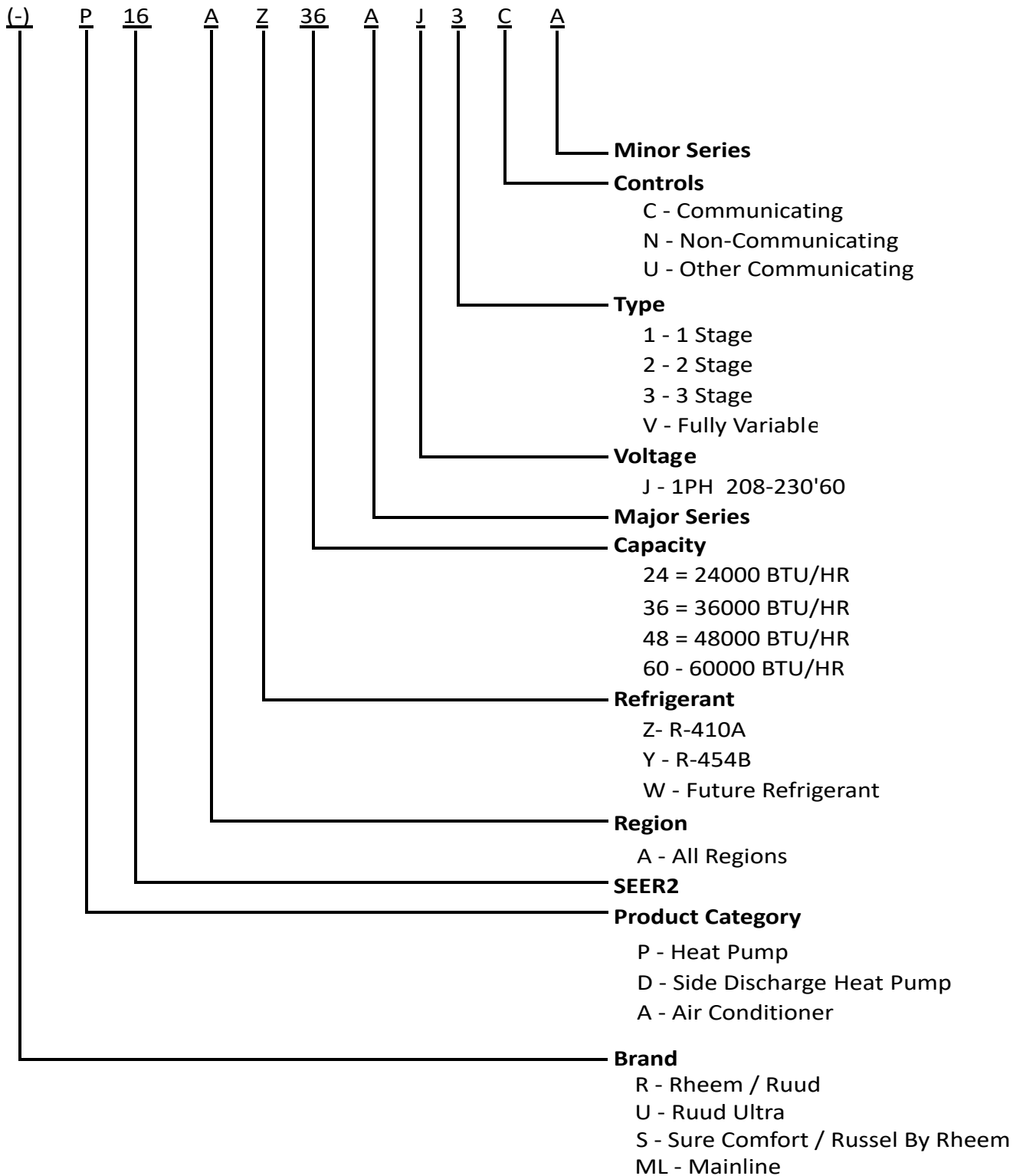

Unit Specifications

# 3.0 UNIT SPECIFICATIONS



## 3.1 Model Number Nomenclature and Available Models (cont.)

AVAILABLE MODELS		
(-)A15AZ24AJ3CA	(-)A16AZ24AJ3CA	(-)P16AZ24AJ3CA
(-)A15AZ36AJ3CA	(-)A16AZ36AJ3CA	(-)P16AZ36AJ3CA
(-)A15AZ48AJ3CA	(-)A16AZ48AJ3CA	(-)P16AZ48AJ3CA
(-)A15AZ60AJ3CA	(-)A16AZ60AJ3CA	(-)P16AZ60AJ3CA



## 3.2 Electrical and Physical Data

### DIMENSIONS

(-)P16AZ	24A	36A	48A	60A
Height "H" inches [cm]	27 [68.6]	35 [88.9]	35 [88.9]	45 [114.3]
Length "L" inches [cm]	29.75 [75.6]	33.75 [85.7]	33.75 [85.7]	35.75 [90.8]
Width "W" inches [cm]	29.75 [75.6]	33.75 [85.7]	33.75 [85.7]	35.75 [90.8]
(-)RA15AZ/(-)A16AZ	24A	36A	48A	60A
Height "H" inches [cm]	27 [68.6]	27 [68.6]	31 [78.7]	31 [78.7]
Length "L" inches [cm]	29.75 [75.6]	33.75 [85.7]	33.75 [85.7]	35.75 [90.8]
Width "W" inches [cm]	29.75 [75.6]	33.75 [85.7]	33.75 [85.7]	35.75 [90.8]

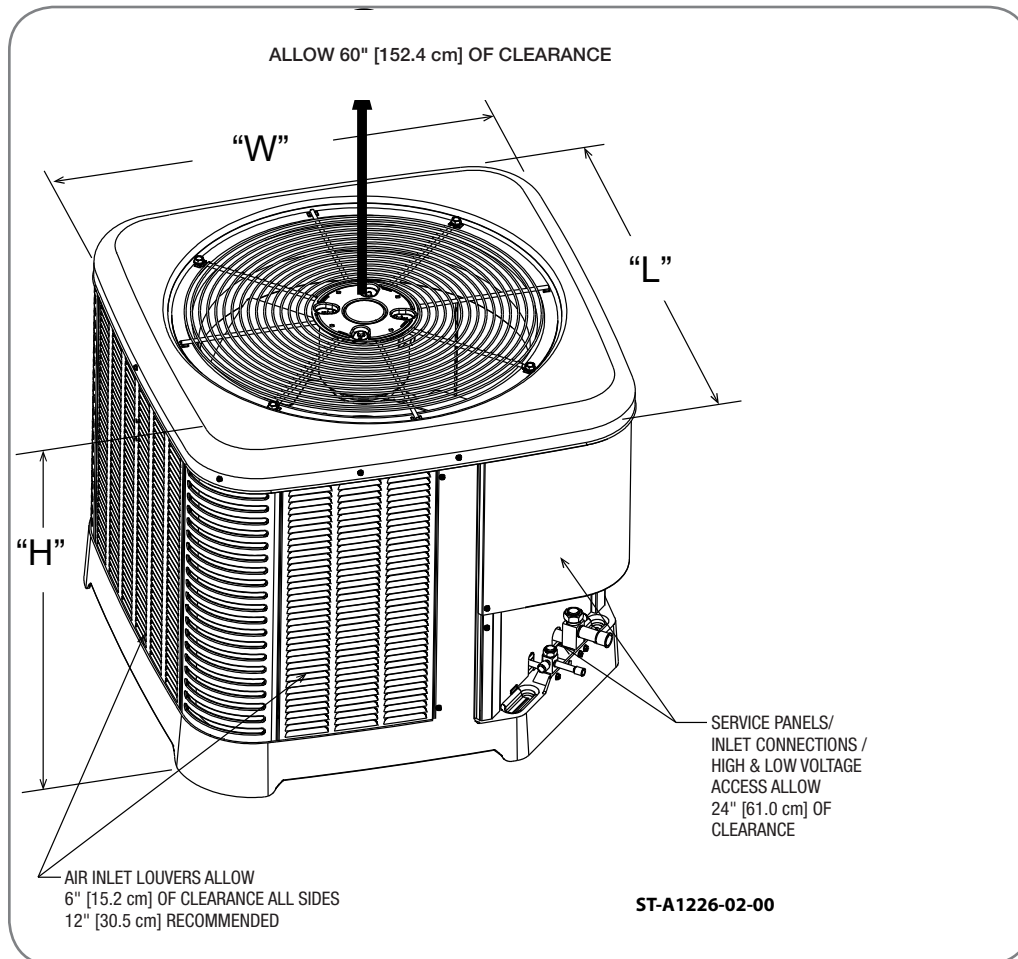

# 4.0 INSTALLATION



## 4.1 Tools and Refrigerant

### 4.1.1 Tools Required for Installing and Servicing R-410A Models

Manifold Sets:

- Up to 800 PSIG [5,516 kPa] High-Side
- Up to 250 PSIG [1,724 kPa] Low-Side
- 550 PSIG [3,792 kPa] Low-Side Retard

Manifold Hoses:

- Service Pressure Rating of 800 PSIG [5,516 kPa]

Recovery Cylinders:

- 400 PSIG [2,758 kPa] Pressure Rating
- Dept. of Transportation 4BA400 or BW400

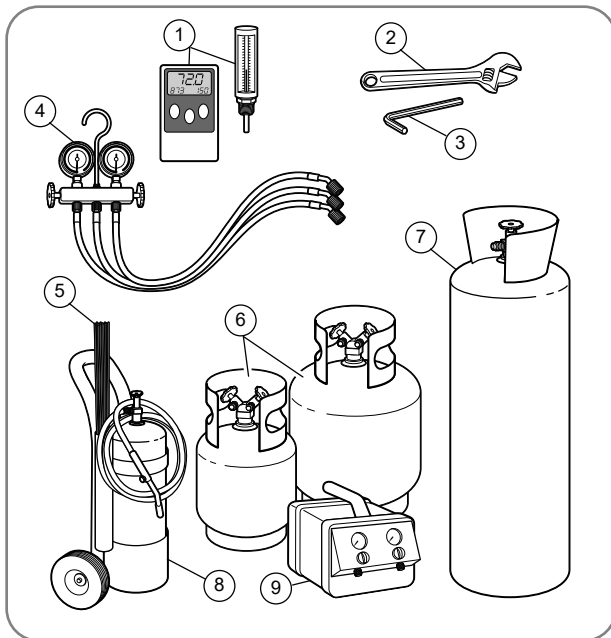

**approximately 60% (1.6 times) greater than R-22.** Recovery and recycle equipment, pumps, hoses, and the like must have design pressure ratings appropriate for R-410A. *Manifold sets need to range up to 800 psig [5,516 kPa] high-side and 250 psig [1,724 kPa] low-side with a 550 psig [3,792 kPa] low-side retard. Hoses need to have a service pressure rating of 800 psig [5,516 kPa]. Recovery cylinders need to have a 400 psig [2,758 kPa] service pressure rating, DOT 4BA400 or DOT BW400.*

**Combustibility:** At pressures above 1 atmosphere, a mixture of R-410A and air can become combustible. **R-410A and air should never be mixed in tanks or supply lines or be allowed to accumulate in storage tanks. Leak checking should never be done with a mixture of R-410A and air.** Leak-checking can be performed safely with nitrogen or a mixture of R-410A and nitrogen.

### 4.1.3 Quick-Reference Guide for R-410A

- R-410A refrigerant operates at approximately 60% higher pressure (1.6 times) than R-22. Ensure that servicing equipment is designed to operate with R-410A.
- R-410A refrigerant cylinders are light rose in color.
- R-410A, as with other HFCs, is only compatible with POE oils.
- Vacuum pumps will not remove moisture from POE oil used in R-410A systems.
- R-410A systems are to be charged with liquid refrigerants. Prior to March 1999, R-410A refrigerant cylinders had a dip tube. These cylinders should be kept upright for equipment charging. Post-March 1999 cylinders do not have a dip tube and should be inverted to ensure liquid charging of the equipment.
- Do not install a suction line filter drier in the liquid line.
- A factory-approved bi-flow liquid line filter drier is shipped with every unit and must be installed in the liquid line at the time of installation. Only manufacturer-approved liquid line filter driers should be used. Filter driers must have a working pressure rating of at least 600 psig [4,137 kPa]. The filter drier will only have adequate moisture-holding capacity if the system is properly evacuated.
- Desiccant (drying agent) must be compatible for POE oils and R-410A refrigerant.

**CAUTION:** R-410A systems operate at higher pressures than R-22 systems. Do not use R-22 service equipment or components on R-410A equipment.

### 4.1.2 Specifications of R-410A

**Application: R-410A is not a drop-in replacement for R-22.** Equipment designs must accommodate its higher pressures. It cannot be retrofitted into R-22 heat pumps.

**Physical Properties:** R-410A has an atmospheric boiling point of -62.9°F [-52.7°C] and its saturation pressure at 77°F [25°C] is 224.5 psig [1,548 kPa].

**Composition:** R-410A is a near-azeotropic mixture of 50% by weight difluoromethane (HFC-32) and 50% by weight pentafluoroethane (HFC-125).

**Pressure: The pressure of R-410A is**



# 4.0 INSTALLATION



## 4.2 Choosing a Location

### 4.2.1 Allowable Clearances

- 12" [30.5 cm] to side intake louvers
- 24" [61.0 cm] to service access panels
- 60" [152.4 cm] vertical for fan discharge

If space limitations exist, the following clearances will have minimal impact to capacity and efficiency and are permitted:

**Single-Unit Applications:** Minimum of 6" [15.2 cm] to side intake louvers. **DO NOT** reduce the 60" [152.4 cm] for fan discharge or the 24" [61.0 cm] service clearances.

**Multiple-Unit Applications:** For units positioned next to each other, a minimum of 6" [15.2 cm] clearance between units is recommended for 2 ton models and 9" [22.9 cm] for 3 ton to 5 ton models. Do not reduce the 60" [152.4 cm] for fan discharge or the 24" [61.0 cm] service clearances.

**IMPORTANT:** Consult local and national building codes and ordinances for special installation requirements. Following location information will provide longer life and simplified servicing of the outdoor heat pump.

**NOTICE:** These units must be installed outdoors. No ductwork can be attached, or other modifications made, to the discharge grille. Modifications will affect performance or operation.

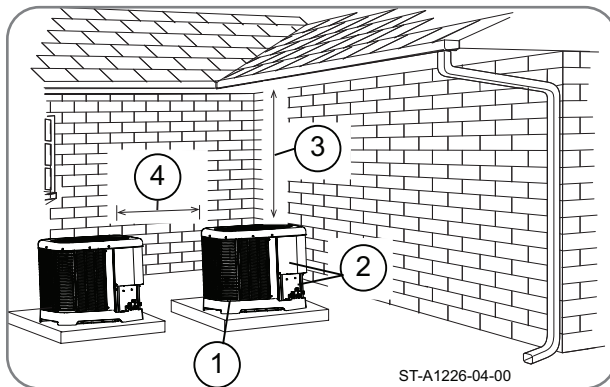

### 4.2.2 Operational Issues Related to Unit Location

**IMPORTANT:** Locate the unit in a manner that will not prevent, impair, or compromise the performance of other equipment installed in proximity to the unit. Maintain all required minimum distances to gas and electric meters, dryer vents, and exhaust and inlet openings. In the absence of national codes or manufacturers' recommendations, local code recommendations and requirements will take precedence.

- Refrigerant piping and wiring should be properly sized and kept as short as possible to avoid capacity losses and increased operating costs.
- Locate the unit where water runoff will not create a problem with the equipment. Position the unit away from the drip edge of the roof whenever possible. Units are weatherized, but can be affected by the following:
  - Water pouring into the unit from the junction of rooflines, without protective gutting. Large volumes of water entering the heat pump while in operation can impact fan blade or motor life, and coil damage may occur to a heat pump if moisture cannot drain from the unit under freezing conditions.
  - Freezing moisture or sleeting conditions can cause the cabinet to ice-over prematurely and prevent heat pump operation, requiring backup heat, which generally results in less economical operation. It is highly recommended to switch the EcoNet™ Control Center or thermostat to the "Emergency Heat" mode during freezing rain or sleeting conditions to prevent damage to the outdoor coil from ice accumulating on the fan blade.
- Closely follow the clearance recommendations in section 4.2.1.
  - 24" [61.0 cm] to the service panel access.
  - 60" [152.4 cm] above the fan discharge (unit top) to prevent recirculation.
  - 6" [15.2 cm] to the coil grille air inlets with 12" [30.5 cm] minimum recommended.

# 4.0 INSTALLATION



## 4.2 Choosing a Location (cont.)

### 4.2.3 Corrosive Environment

The metal parts of this unit may be subject to rust or deterioration if exposed to a corrosive environment. This oxidation could shorten the equipment's useful life.

Corrosive elements include, but are not limited to, salt spray, fog or mist in seacoast areas, sulphur or chlorine from lawn watering systems, and various chemical contaminants from industries such as paper mills and petroleum refineries.

If the unit is to be installed in an area where contaminants are likely to be a problem, special attention should be given to the equipment location and exposure.

- Avoid having lawn sprinkler heads spray directly on the unit cabinet.
- In coastal areas, locate the unit on the side of the building away from the waterfront.
- Shielding provided by a fence or shrubs may give some protection, but cannot violate minimum airflow and service access clearances.

**⚠WARNING:** Disconnect all power to unit before starting maintenance. Failure to do so can cause electrical shock resulting in severe personal injury or death.

Regular maintenance will reduce the buildup of contaminants and help to protect the unit's finish.

- Frequent washing of the cabinet, fan blade, and coil with fresh water will remove most of the salt or other contaminants that build up on the unit.
- Regular cleaning and waxing of the cabinet with a good automobile polish will provide some protection.
- A good liquid cleaner may be used several times a year to remove matter that will not wash off with water.

### 4.2.4 Customer Satisfaction Issues

- The heat pump should be located away from the living, sleeping, and recreational spaces of the owner and those spaces on adjoining property.
- To prevent noise transmission, the mounting pad for the outdoor unit should not be connected to the structure and should be located a sufficient distance above grade to prevent ground water from entering the unit.

## 4.3 Unit Mounting

### 4.3.1 Unit Mounting Methods

The outdoor heat pump unit may be mounted in a number of ways. The most common method is on the ground mounted on a concrete or pre-fabricated pad. It can also be mounted on a ground or roof mounted metal frame, wooden frame, or 4" x 4" [10.2 cm x 10.2 cm] wooden stringers. It is extremely important to properly secure the unit to the pad or frame so it does not shift during high winds, seismic events, or other outside forces to eliminate the possibility of a safety hazard or physical damage to the unit. Local codes in regions subject to frequent hurricanes and seismic events will dictate specific mounting requirements and must be followed. It is also important to elevate the heat pump in areas that receive a significant amount of snowfall so accumulated snow does not block the outdoor coil and interfere with drainage of water during the defrost cycle. Refer to Section 4.3.4 for typical ground snow levels for different regions of the USA.

### 4.3.2 High Wind and Seismic Tie-Down Methods

The manufacturer-approved/recommended method is a guide to securing equipment for wind and seismic loads. Other methods might provide the same result, but the manufacturer method is the only one endorsed by the manufacturer for securing equipment where wind or earthquake damage can occur. Additional information is available on the manufacturer's website or from the wholesale distributor.

# 4.0 INSTALLATION

## 4.3.3 Elevating Unit

**⚠ WARNING:** Secure an elevated unit and its elevating stand in order to prevent tipping. Failure to do so may result in severe personal injury or death.

If elevating the heat pump, either on a flat roof or on a slab, observe the following guidelines.

- If elevating a unit on a flat roof, use 4" x 4" [10.2 cm x 10.2 cm] or equivalent stringers positioned to distribute unit weight evenly and prevent noise and vibration.
- Heat pump products will need to be elevated per local climate and code requirements to provide clearance above the estimated snowfall level to ensure the unit will be protected from damage. Failure to follow these instructions may result in equipment damage and improper operation.

**NOTICE:** Do not block drain openings on bottom of unit.

- If unit must be elevated because of anticipated snowfall, secure unit and elevating stand such that unit and/or stand will not tip over or fall off. Keep in mind that someone may try to climb on unit.

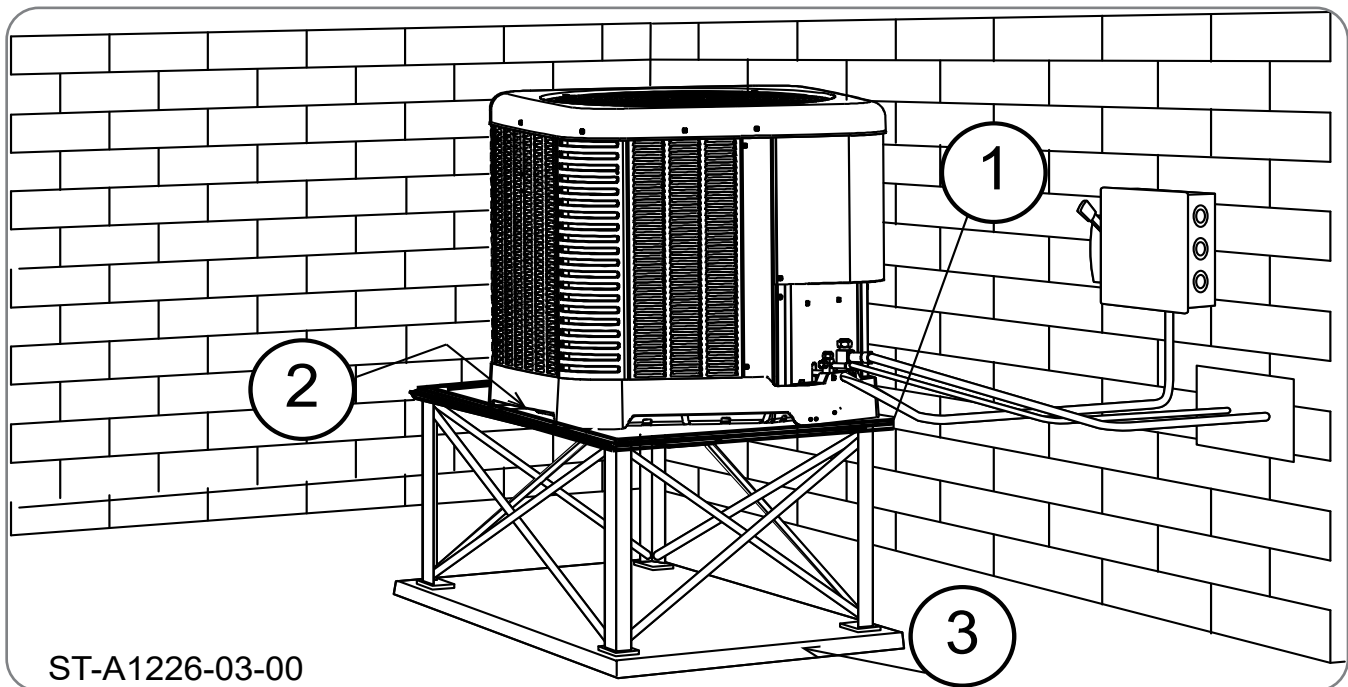

# 4.0 INSTALLATION



## 4.4 Refrigerant Line Set Selection

### 4.4.1 Replacing Existing Systems

To prevent failure of a new unit, the existing line set must be correctly sized for the new unit and must be cleaned or replaced. Care must be taken so the expansion device is not plugged. For new and replacement units, a liquid line filter drier must be installed and the line set must be properly sized. Test the oil for acid. If it tests positive for acid, a suction line filter drier is mandatory.

**IMPORTANT:** When replacing an R-22 unit with an R-410A unit, either replace the line set or ensure that residual mineral oil is drained from existing lines including oil trapped in low spots.

### 4.4.2 Line Set Application Considerations

The following are special considerations that need to be addressed when selecting and installing a line set.

- Additional refrigerant charge
- Fitting losses and maximum equivalent length considerations
- Refrigerant migration during the off cycle
- Oil return to the compressor
- Capacity losses
- System oil level adjustment

#### 4.4.2.1 Oil Return to Compressor

Small amounts of compressor crankcase oil is picked up and carried out of the compressor by the moving refrigerant and is circulated through the system along with the refrigerant before it returns to the compressor crankcase. It is critical to the life of the compressor for the oil to be able to return to the compressor to maintain an adequate level of oil in the compressor crankcase. Oversized vapor lines result in inadequate refrigerant velocities to carry the oil along with the refrigerant and will cause the oil to accumulate in the low spots in the vapor line instead of being returned to the compressor crankcase. This is especially true for long line lengths. Variable speed systems present an additional challenge due to the fact that the system operates at a significantly reduced refrigerant flow rate for a significant percentage of operating time. Only use the vapor line sizes listed in Table 2 to assure proper oil return. **DO NOT** oversize vapor line!

#### 4.4.2.2 Refrigerant Migration During Off Cycle

Long line set applications can require a considerable amount of additional refrigerant. This additional refrigerant needs to be managed throughout the entire ambient operating envelope that the system will go through during its life cycle. Off-Cycle migration is where excess refrigerant condenses and migrates to the coldest and/or lowest part of the system. Excessive build-up of refrigerant at the compressor will result in poor reliability and noisy operation during startup. Section 4.5.2 demonstrates the required unit configuration for different applications.

#### 4.4.2.3 Maximum Liquid Pressure Drop

The total liquid line pressure drop must not exceed 50 psig [345 kPa] to assure a solid column of liquid at the metering device and stable control of superheat. Be sure to account for vertical separation, elbows, filter driers, solenoid valves, sight glasses, and check valves when calculating liquid line pressure drop.

#### 4.4.2.4 Liquid Line Refrigerant Flashing

Excessive pressure drop and heat gain in long liquid lines can result in the refrigerant flashing into a vapor before it reaches the expansion device which will dramatically reduce the capacity and efficiency of the system. For this reason, the liquid line must be sized properly using Table 2 and must be insulated in unconditioned spaces.



# 4.0 INSTALLATION

## 4.4.2.5 Oil Level Adjustment for Long Line Set Applications

Additional oil may need to be added if refrigerant is added during installation. If the system contains more than 20 lbs [9 kg] of refrigerant charge, add 1 fluid oz of POE oil for every 5 lbs [13 ml/kg] of refrigerant charge over 20 lbs [9 kg].

## 4.4.2.6 Capacity Losses

Long line lengths can result in a reduction in capacity due to vapor line pressure drop and heat gain or loss. Refer to Table 2 for capacity loss multipliers for various vapor line diameters and equipment line lengths. This table does not account for any capacity loss due to heat gain or loss from the environment. It is extremely important not to oversize the vapor line to minimize capacity loss at the expense of proper oil return. If the table shows an “NR” for a particular vapor line diameter and length, or, if a vapor line diameter is not listed, oil return will not be adequate.

## 4.4.3 Line Set Length and Fitting Losses

Refrigerant tubing is measured in terms of actual length and equivalent length. Actual length is used for refrigerant charge applications. Equivalent length takes into account pressure losses from tubing length, fittings,

vertical separation, accessories, and filter driers. The table below references different commonly used equivalent lengths.

Table 1

Line Size in [mm]	90° Short Radius Elbow	90° Long Radius Elbow	45° Elbow	Solenoid Valve	Check Valve	Sight Glass	Filter Drier
3/8 [9.53]	1.3 [0.40]	0.8 [0.24]	0.3 [0.09]	6 [1.83]	4 [1.22]	0.4 [0.12]	6 [1.83]
1/2 [12.71]	1.4 [0.43]	0.9 [0.27]	0.4 [0.12]	9 [2.74]	5 [1.52]	0.6 [0.18]	6 [1.83]
5/8 [15.88]	1.5 [0.46]	1 [0.30]	0.5 [0.15]	12 [3.66]	6 [1.83]	0.8 [0.24]	6 [1.83]
3/4 [19.05]	1.9 [0.58]	1.3 [0.40]	0.6 [0.18]	14 [4.27]	7 [2.13]	0.9 [0.27]	6 [1.83]
7/8 [22.23]	2.3 [0.70]	1.5 [0.46]	0.7 [0.21]	15 [4.57]	8 [2.44]	1 [0.30]	6 [1.83]
1-1/8 [28.58]	2.7 [0.82]	1.8 [0.55]	0.9 [0.27]	22 [6.71]	12 [3.66]	1.5 [0.46]	6 [1.83]

# 4.0 INSTALLATION

## 4.4.4 Liquid Line Selection

The purpose of the liquid line is to transport warm sub-cooled liquid refrigerant between the outdoor unit to the indoor unit in the cooling mode. In the heating mode, the liquid line returns sub-cooled liquid from the indoor unit to the outdoor unit. It is important not to allow the refrigerant to flash into superheated vapor prior to entering the expansion device of the indoor coil or outdoor unit. Flashing of refrigerant can occur for the following reasons:

- Low refrigerant charge
- Improperly selected liquid line size
- Absorption of heat prior to expansion device
- Excessive vertical separation between the outdoor unit and indoor coil
- Restricted liquid linear filter drier
- Kinked liquid line

The total pressure drop allowed for the liquid line is 50 PSI [345 kPa]. The procedure for selecting the proper liquid line is as follows:

- Measure the total amount of vertical separation between the outdoor unit and indoor coil.

- Measure the total indoor length of liquid line required.
- Add all of the equivalent lengths associated with any fittings or accessories using Table 1.
- Add the linear length to the total fitting equivalent length. This will equal your total equivalent line length.
- Reference Table 2 to verify the calculated equivalent length is acceptable with the required vertical separation and diameter of liquid line.

**Example:** A 3-ton heat pump unit is installed 25' below the indoor unit, requires a 75' of 1/2" diameter liquid line, 3/4" vapor line, 4 90° LR elbows and a filter drier.

- Fitting Equivalent Length (ft.) =  $4 \times .9' + 6' = 9.6'$
  - Total Equivalent Length (ft.) =  $75' + 9.6' = 84.6'$
- This application is acceptable because the 25' vertical rise is less than the maximum rise of 50' for this application.

Example Table (Excerpt from Table 2A)

Unit Size	Allowable Liquid Line Size	Allowable Vapour Line Size	Outdoor Unit ABOVE or BELOW Indoor Unit Equivalent Length (Feet)					
			< 25	26-50	51-75	76-100	101-125	126-150
			Maximum Vertical Separation / Capacity Multiplier					
3 Ton	5/16"	5/8"	25 / 0.99	50 / 0.97	50 / 0.95	50 / 0.93	36 / 0.91	NR
	3/8"	5/8"	25 / 0.99	50 / 0.97	50 / 0.95	50 / 0.93	50 / 0.91	NR
	5/16"	3/4"	25 / 1.00	50 / 0.99	50 / 0.99	50 / 0.98	36 / 0.97	20 / 0.96
	3/8"	3/4"	25 / 1.00	50 / 0.99	50 / 0.99	50 / 0.98	50 / 0.97	50 / 0.96
	1/2"	3/4"	25 / 1.00	50 / 0.99	50 / 0.99	50 / 0.98	50 / 0.97	50 / 0.96

## 4.4.5 Vapor Line Selection

The purpose of the vapor line is to return superheated vapor to the condensing unit from the indoor coil in the cooling mode. While in the heating mode, the vapor line transports discharge vapor to the indoor coil from the outdoor unit. Proper vapor line sizing is important because it plays an important role in returning oil to the compressor to prevent potential damage to the bearings, valves, and scroll sets. Also, an improperly sized vapor line can dramatically reduce capacity and performance of the system. The procedure for selecting the proper vapor line is as follows:

- Determine the total linear length of vapor line required.
- Add all of the equivalent lengths associated with any fittings or accessories using Table 1.
- Add the linear length and total fitting equivalent length. This will equal your total equivalent line length.
- Reference Table 2 to verify that the calculated equivalent length falls within the compatibility region of the chart.
- Verify capacity loss is acceptable for the application.

# 4.0 INSTALLATION

Table 2A: Refrigerant Line Sizing Chart (English Units)

15/16 SEER2 Variable Speed Heat Pumps/Air Conditioner								
Unit Size	Allowable Liquid Line Size	Allowable Vapour Line Size	Outdoor Unit ABOVE or BELOW Indoor Unit Equivalent Length (Feet)					
			< 25	26-50	51-75	76-100	101-125	126-150
			Maximum Vertical Separation / Capacity Multiplier					
2.0 Ton <b>*SEE NOTE 3</b>	1/4"	5/8"	25 / 1.00	50 / 0.99	33 / 0.98	6 / 0.97	NR	NR
	5/16"	5/8"	25 / 1.00	50 / 0.99	33 / 0.98	50 / 0.97	50 / 0.96	50 / 0.95
	3/8"	5/8"	25 / 1.00	50 / 0.99	33 / 0.98	50 / 0.97	50 / 0.96	50 / 0.95
	1/4"	3/4" *	25 / 1.00	50 / 1.00	33 / 0.99	6 / 0.99	NR	NR
	5/16"	3/4" *	25 / 1.00	50 / 1.00	50 / 0.99	50 / 0.99	50 / 0.99	50 / 0.98
	3/8"	3/4" *	25 / 1.00	50 / 1.00	50 / 0.99	50 / 0.99	50 / 0.99	50 / 0.98
3 Ton	5/16"	5/8"	25 / 0.99	50 / 0.97	50 / 0.95	50 / 0.93	36 / 0.91	NR
	3/8"	5/8"	25 / 0.99	50 / 0.97	50 / 0.95	50 / 0.93	50 / 0.91	NR
	5/16"	3/4"	25 / 1.00	50 / 0.99	50 / 0.99	50 / 0.98	36 / 0.97	20 / 0.96
	3/8"	3/4"	25 / 1.00	50 / 0.99	50 / 0.99	50 / 0.98	50 / 0.97	50 / 0.96
	1/2"	3/4"	25 / 1.00	50 / 0.99	50 / 0.99	50 / 0.98	50 / 0.97	50 / 0.96
4 Ton	3/8"	3/4"	25 / 0.99	50 / 0.98	50 / 0.96	50 / 0.95	50 / 0.93	50 / 0.92
	1/2"	3/4"	25 / 0.99	50 / 0.98	50 / 0.96	50 / 0.95	50 / 0.93	50 / 0.92
	3/8"	7/8"	25 / 1.00	50 / 0.99	50 / 0.99	50 / 0.98	50 / 0.98	50 / 0.97
	1/2"	7/8"	25 / 1.00	50 / 0.99	50 / 0.99	50 / 0.98	50 / 0.98	50 / 0.97
5 Ton <b>**SEE NOTE 4</b>	3/8"	3/4"	25 / 0.98	50 / 0.97	50 / 0.95	50 / 0.93	46 / 0.91	NR
	1/2"	3/4"	25 / 0.98	50 / 0.97	50 / 0.95	50 / 0.93	50 / 0.91	NR
	3/8"	7/8"	25 / 0.99	50 / 0.99	50 / 0.98	50 / 0.97	50 / 0.96	38 / 0.95
	1/2"	7/8"	25 / 0.99	50 / 0.99	50 / 0.98	50 / 0.97	50 / 0.96	50 / 0.95
	3/8"	1-1/8" **	25 / 1.00	50 / 1.00	50 / 1.00	50 / 0.99	50 / 0.99	38 / 0.99
	1/2"	1-1/8" **	25 / 1.00	50 / 1.00	50 / 1.00	50 / 0.99	50 / 0.99	50 / 0.99

Notes:

- 1) Do not exceed 150 ft linear line length.
- 2) Do not exceed 50 ft vertical separation between indoor and outdoor units.
- 3) \* 3/4" vapour line should only be used for 2 ton systems if outdoor unit is below or at same level as indoor unit to assure proper oil return.
- 4) \*\* 1-1/8" vapour line should only be used for 5 ton systems if outdoor unit is below or at same level as indoor unit to assure proper oil return.
- 5) Always use the smallest liquid line allowable to minimize refrigerant charge.
- 6) Applications shaded in light Gray indicate capacity multipliers between 0.90 and 0.96 which are not recommended, but are allowed.
- 7) Applications shaded in dark Gray are not recommended due to excessive liquid or suction pressure drop.

# 4.0 INSTALLATION

Table 2B: Refrigerant Line Sizing Chart (Metric Units)

15/16 SEER2 Variable Speed Heat Pumps/Air Conditioner								
Unit Size	Allowable Liquid Line Size mm [in.]	Allowable Vapour Line Size mm [in.]	Outdoor Unit ABOVE or BELOW Indoor Unit Equivalent Length (Feet)					
			< 8	8-15	16-23	24-30	31-38	39-46
			Maximum Vertical Separation / Capacity Multiplier					
7.0 KW [2.0 Ton] <b>*SEE NOTE 3</b>	6.35 [1/4]	15.88 [5/8]	8 / 1.00	15 / 0.99	10 / 0.98	2 / 0.97	NR	NR
	7.94 [5/16]	15.88 [5/8]	8 / 1.00	15 / 0.99	15 / 0.98	15 / 0.97	15 / 0.96	15 / 0.95
	9.53 [3/8]	15.88 [5/8]	8 / 1.00	15 / 0.99	15 / 0.98	15 / 0.97	15 / 0.96	15 / 0.95
	6.35 [1/4]	19.05 [3/4] *	8 / 1.00	15 / 0.99	10 / 0.99	2 / 0.99	NR	NR
	7.94 [5/16]	19.05 [3/4] *	8 / 1.00	15 / 0.99	15 / 0.99	15 / 0.99	15 / 0.99	15 / 0.98
	9.53 [3/8]	19.05 [3/4] *	8 / 1.00	15 / 0.99	15 / 0.99	15 / 0.99	15 / 0.99	15 / 0.98
10.6 KW [3 Ton]	7.94 [5/16]	15.88 [5/8]	8 / 0.99	15 / 0.97	15 / 0.95	15 / 0.93	11 / 0.91	NR
	9.53 [3/8]	15.88 [5/8]	8 / 0.99	15 / 0.97	15 / 0.95	15 / 0.93	15 / 0.91	NR
	7.94 [5/16]	19.05 [3/4]	8 / 1.00	15 / 0.99	15 / 0.99	15 / 0.98	11 / 0.97	6 / 0.96
	9.53 [3/8]	19.05 [3/4]	8 / 1.00	15 / 0.99	15 / 0.99	15 / 0.98	15 / 0.97	15 / 0.96
	12.7 [1/2]	19.05 [3/4]	8 / 1.00	15 / 0.99	15 / 0.99	15 / 0.98	15 / 0.97	15 / 0.96
14.1 KW [4 Ton]	9.53 [3/8]	19.05 [3/4]	8 / 0.99	15 / 0.98	15 / 0.96	15 / 0.95	15 / 0.93	15 / 0.92
	12.7 [1/2]	19.05 [3/4]	8 / 0.99	15 / 0.98	15 / 0.96	15 / 0.95	15 / 0.93	15 / 0.92
	9.53 [3/8]	22.23 [7/8]	8 / 1.00	15 / 0.99	15 / 0.99	15 / 0.98	15 / 0.98	15 / 0.97
	12.7 [1/2]	22.23 [7/8]	8 / 1.00	15 / 0.99	15 / 0.99	15 / 0.98	15 / 0.98	15 / 0.97
17.6 KW [5 Ton] <b>**SEE NOTE 4</b>	9.53 [3/8]	19.05 [3/4]	8 / 0.98	15 / 0.97	15 / 0.95	15 / 0.93	14 / 0.91	NR
	12.7 [1/2]	19.05 [3/4]	8 / 0.98	15 / 0.97	15 / 0.95	15 / 0.93	15 / 0.91	NR
	9.53 [3/8]	22.23 [7/8]	8 / 0.99	15 / 0.99	15 / 0.98	15 / 0.97	15 / 0.96	12 / 0.95
	12.7 [1/2]	22.23 [7/8]	8 / 0.99	15 / 0.99	15 / 0.98	15 / 0.97	15 / 0.96	15 / 0.95
	9.53 [3/8]	28.58 [1-1/8] **	8 / 1.00	15 / 1.00	15 / 1.00	15 / 0.99	15 / 0.99	12 / 0.99
	12.7 [1/2]	28.58 [1-1/8] **	8 / 1.00	15 / 1.00	15 / 1.00	15 / 0.99	15 / 0.99	15 / 0.99

Notes:

- 1) Do not exceed 46 meters linear line length.
- 2) Do not exceed 15 meters vertical separation between indoor and outdoor units.
- 3) \*19.05mm [3/4 in.] vapour line should only be used for 2 ton systems if outdoor unit is below or at same level as indoor unit to assure proper oil return.
- 4) \*\*28.58mm [1-1/8 in.] vapour line should only be used for 5 ton systems if outdoor unit is below or at same level as indoor unit to assure proper oil return.
- 5) Always use the smallest liquid line allowable to minimize refrigerant charge.
- 6) Applications shaded in light Gray indicate capacity multipliers between 0.90 and 0.96 which are not recommended, but are allowed.
- 7) Applications shaded in dark Gray are not recommended due to excessive liquid or suction pressure drop.

Tubing

Additional Oil, Oz. 16 SEER2 Heat Pump											
Lineset Length, Ft	50	60	70	80	90	100	110	120	130	140	150
2T	N/A	1	3	4	5	7	8	9	11	12	13
3T	N/A	N/A	N/A	N/A	1	2	3	5	6	7	9
4T	N/A	N/A	N/A	N/A	N/A	N/A	N/A	N/A	N/A	0	1
5T	2	3	4	6	7	8	10	11	12	14	15



# 4.0 INSTALLATION

Additional Oil, Oz. 15/16 SEER2 Air Conditioner											
Lineset Length, Ft	50	60	70	80	90	100	110	120	130	140	150
2T	N/A	N/A	N/A	N/A	N/A	1	2	3	5	6	7
3T	N/A	N/A	N/A	N/A	N/A	N/A	1	2	3	5	6
4T	N/A	N/A	N/A	N/A <td N/A	N/A	N/A	N/A	N/A	N/A	N/A	
5T	N/A	N/A	N/A	N/A	N/A	N/A	N/A	N/A	N/A	N/A	N/A

## 4.5 Line Set Installation

- If tubing is to be run underground, it must be run in a sealed watertight chase.
- Use care in routing tubing and do not kink or twist. Use a good quality tubing bender on the vapor line to prevent kinking.

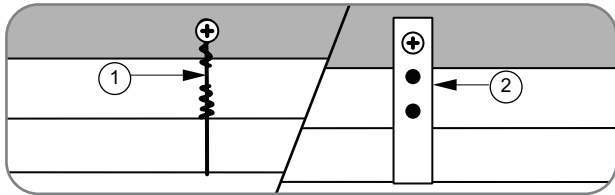

- Route the tubing using temporary hangers; then straighten the tubing and install permanent hangers. The tubing must be adequately supported.
- Isolate the vapor line from the building structure. If the vapor line comes in contact with inside walls, ceiling, or flooring, the vibration of the vapor line

in the heating mode will result in noise inside the structure.

- Blow out the liquid and vapor lines with dry nitrogen before connecting to the outdoor unit and indoor coil to remove debris that can plug the expansion device.

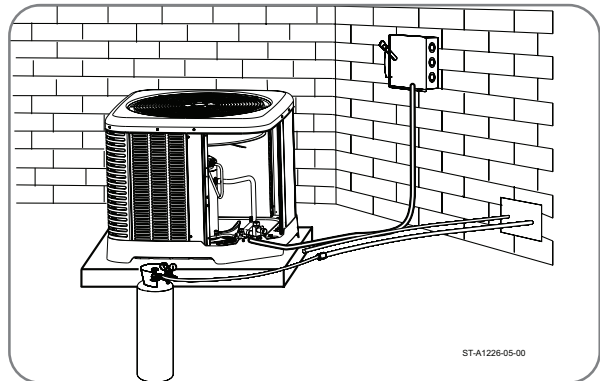

### 4.5.1 Important Tubing Installation Practices

Observe the following when installing correctly sized type "L" refrigerant tubing between the outdoor unit and indoor coil:

- Check Table 2 for the correct vapor line size and liquid line size.
- **If a portion of the liquid line passes through a very hot area where liquid refrigerant can be heated to form vapor, insulating the liquid line is required.**
- Use clean, dehydrated, sealed refrigeration-grade tubing.
- Always keep tubing sealed until tubing is in place and connections are to be made.
- A high-quality biflow filter drier is included with all R-410A heat pump units and must be installed in the liquid line upon unit installation.
- When replacing an R-22 system with an R-410A system and the line set is not replaced, blow out the lines with dry nitrogen to remove as much of the remaining mineral oil as possible. Check for low spots where oil may be trapped and take measures to drain the oil from those areas.

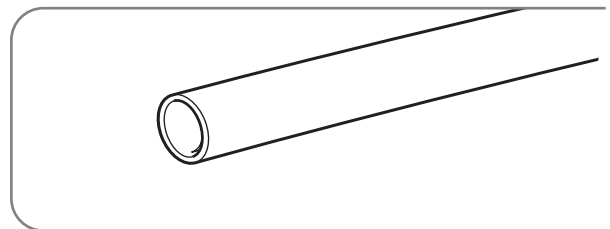

- If tubing has been cut, deburr the ends while holding the tubing in a position to prevent chips from falling into tubing. Burrs such as those caused by tubing cutters can affect performance dramatically, particularly on small diameter liquid lines.
- For best operation, keep tubing run as short as possible with a minimum number of elbows or bends.
- Locations where the tubing will be exposed to mechanical damage should be avoided. If it is necessary to use such locations, the copper tubing should be protected by a housing to prevent damage.

# 4.0 INSTALLATION



## 4.5 Line Set Installation (cont.)

### 4.5.2 Relative Location of Indoor and Outdoor Units

#### 4.5.2.1 Outdoor Unit Level or Near Level to Indoor Coil Line Set

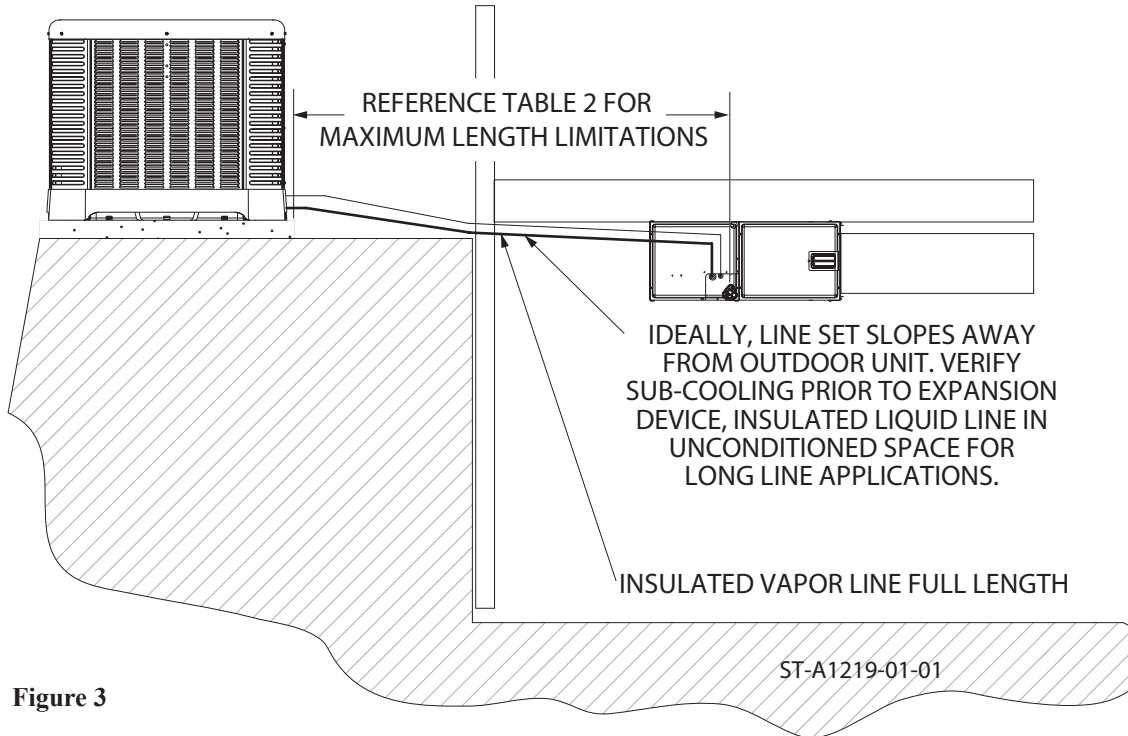

Figure 3

For applications with the outdoor unit and indoor unit on the same level the following is required:

- Insulated liquid line in unconditioned space only.
- Insulated vapor line full length.
- Vapor line should slope toward the indoor unit. (Reference Figure 3)
- Follow the proper line sizing, maximum linear and equivalent length, charging requirements, and oil level adjustments spelled out in this document.
- Verify at least 5°F [2.8°C] sub-cooling at the indoor unit prior to expansion device.

# 4.0 INSTALLATION

## 4.5.2.2 Outdoor Unit Below Indoor Coil (Long Line Set Applications)

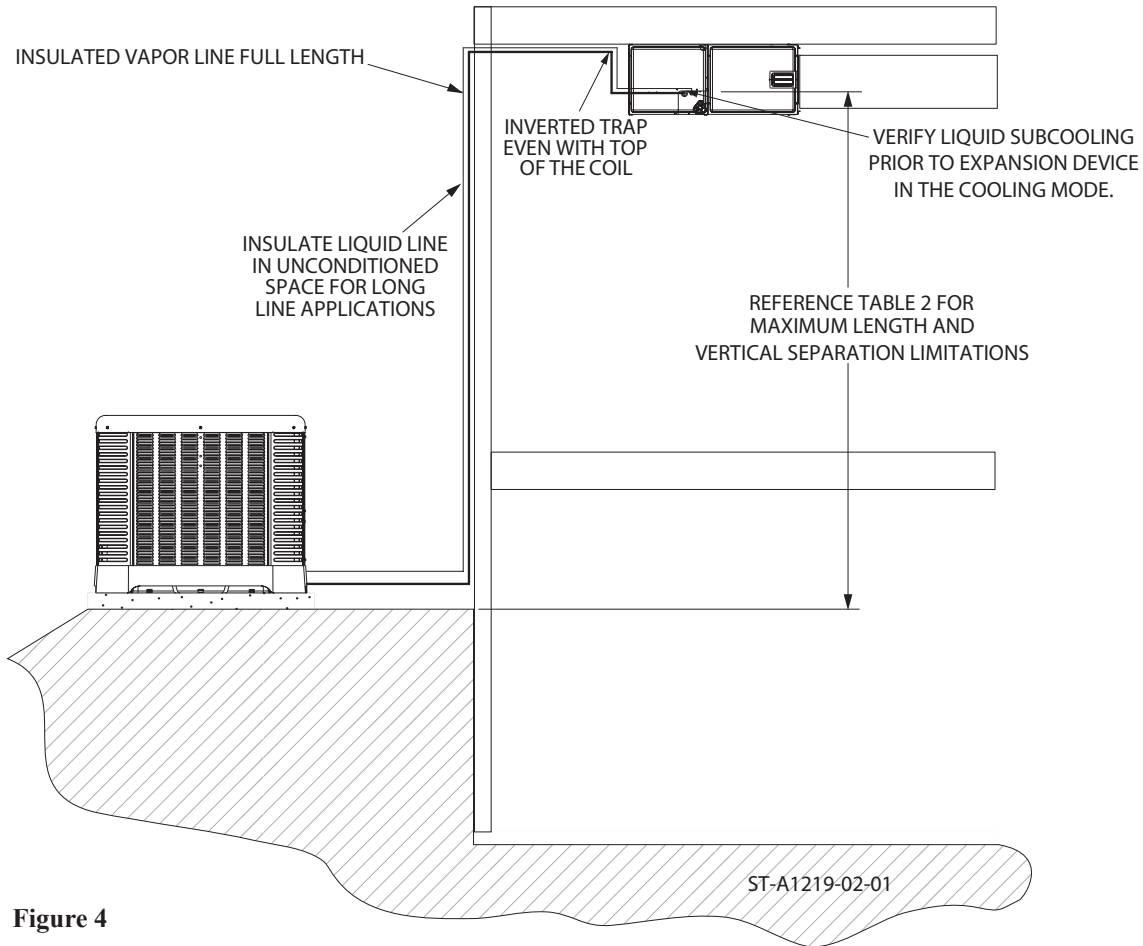

Figure 4

For applications with the outdoor unit below the indoor coil, the following is required:

- Inverted vapor-line trap (Reference Figure 4)
- Insulated liquid line in unconditioned space only.
- Insulated vapor line full length.
- Follow the proper line sizing, maximum linear and equivalent length, maximum vertical separation, charging requirements, and oil level adjustments spelled out in this document.
- Measure pressure at the liquid line service valve and prior to expansion device. Verify that the pressure drop is not greater than 50 PSI [345 kPa].
- For elevations greater than 25' [8 m] a lower subcooling can be expected.
- Verify there is at least 5°F [2.8°C] of liquid subcooling at the indoor coil prior to the expansion device.

# 4.0 INSTALLATION

## 4.5.2.3 Outdoor Unit Above Indoor Coil

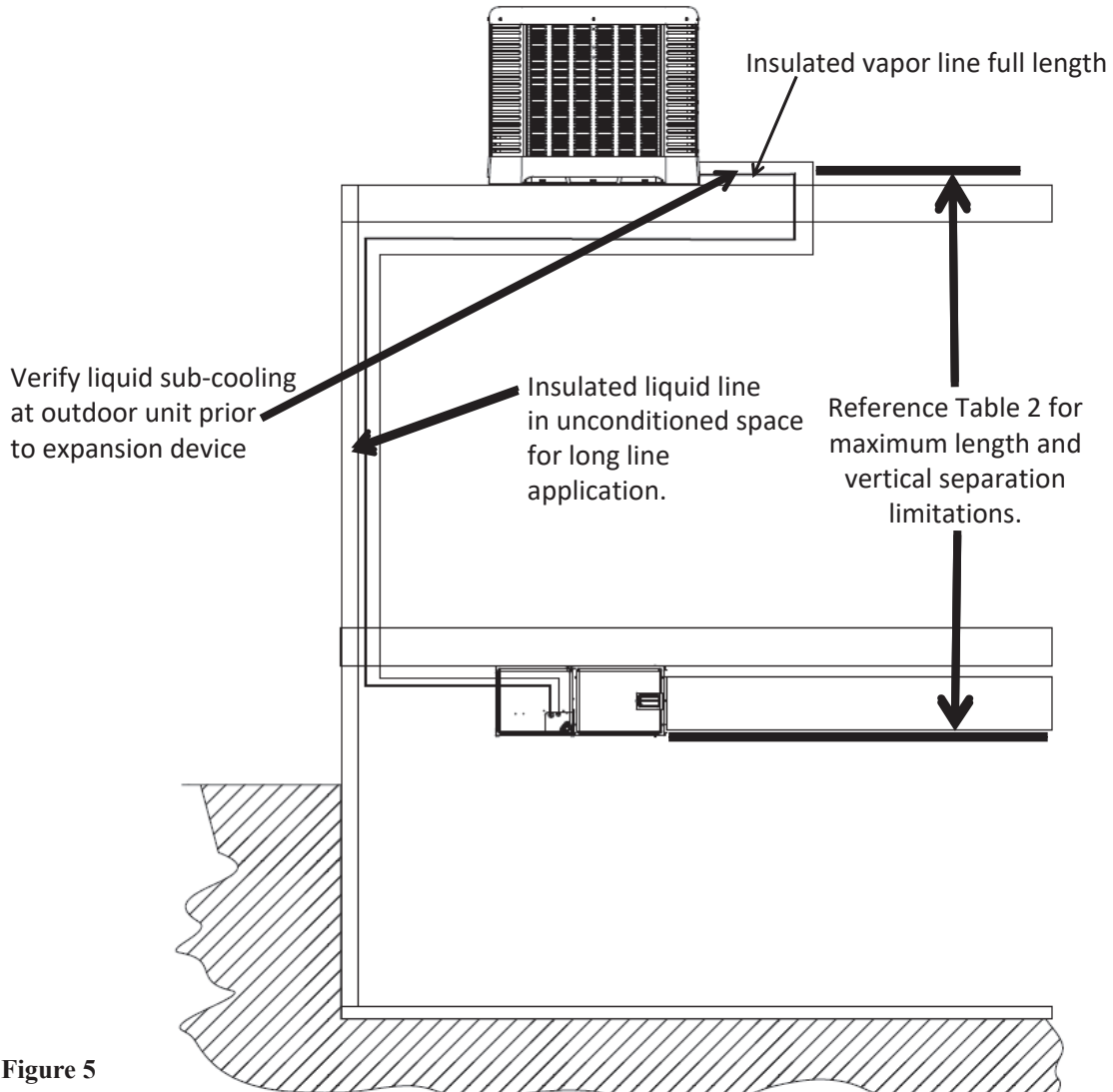

Figure 5

For applications with the outdoor unit above the indoor coil the following is required:

- Insulated liquid line in unconditioned space only.
- Follow the proper line sizing, maximum linear and equivalent length, maximum vertical separation, charging requirements, and oil level adjustments spelled out in this document.

- Insulated vapor line full length.
- Verify at least 5°F [2.8°C] of liquid subcooling at the outdoor unit prior to expansion device in the heating mode.



# 4.0 INSTALLATION

## 4.5.3 Tubing Connections

Indoor coils have only a holding charge of dry nitrogen. Keep all tube ends sealed until connections are to be made.

- Use type “L” copper refrigeration tubing. Braze the connections with the following alloys:
  - Copper to copper, 5% silver minimum
  - Copper to steel or brass, 15% silver minimum

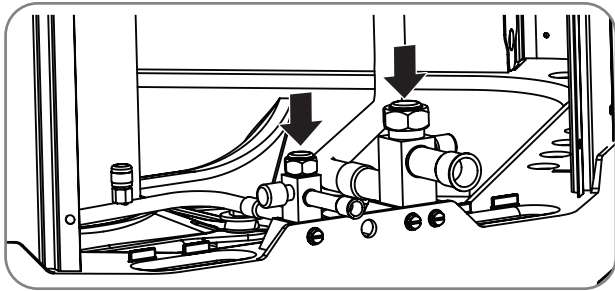

- Be certain both refrigerant shutoff valves at the outdoor unit are closed.

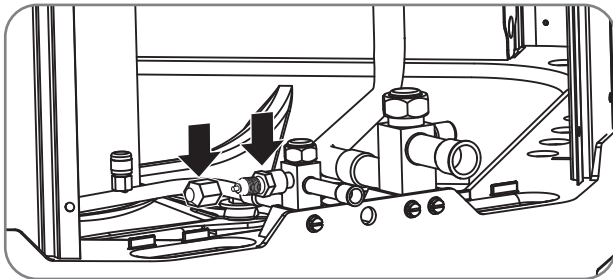

- Remove the caps and Schrader cores from the pressure ports to protect seals from heat damage. Both the Schrader valves and the service valves have seals that may be damaged by excessive heat.

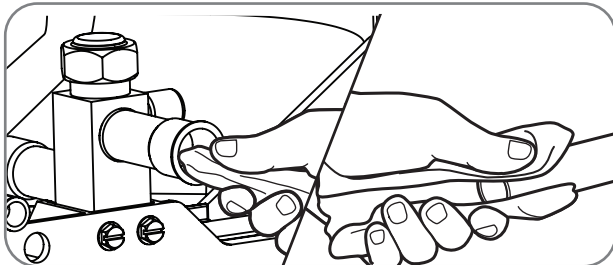

- Clean the inside of the fittings and outside of the tubing with a clean, dry cloth before soldering. Clean out debris, chips, dirt, etc., that enters tubing or service valve connections.

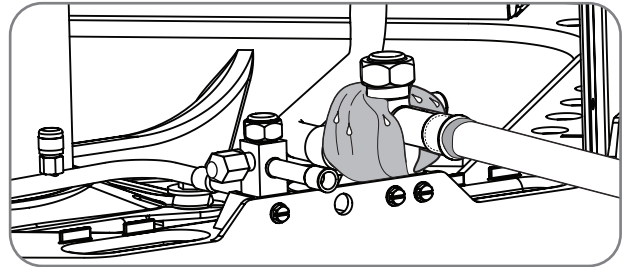

- Wrap valves with a wet rag or thermal barrier compound before applying heat.

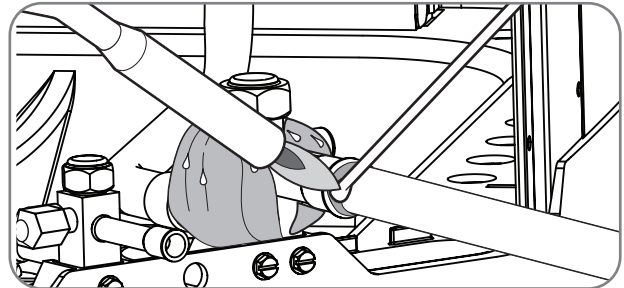

- Braze the tubing between the outdoor unit and indoor coil. Flow dry nitrogen into a pressure port and through the tubing while brazing, but do not allow pressure inside tubing which can result in leaks. Once the system is full of nitrogen, the nitrogen regulator should be turned off to avoid pressuring the system.

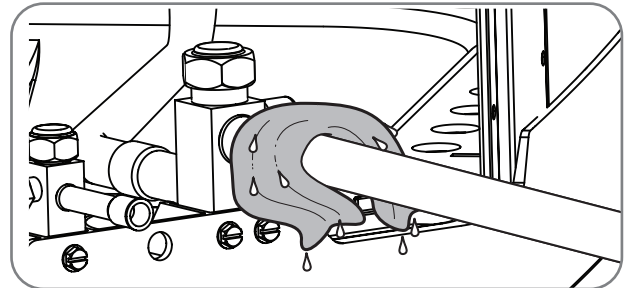

- After brazing, use an appropriate heatsink material to cool the joint.
- Reinstall the Schrader cores into both pressure ports.

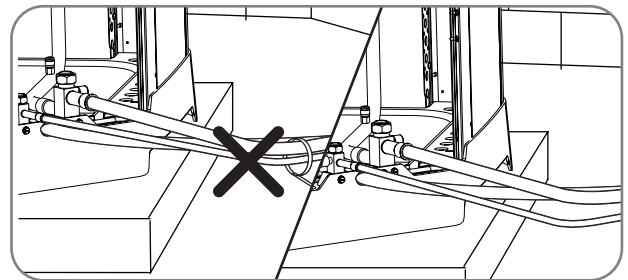

- Do not allow the bare vapor line and liquid line to be in contact with each other. This causes an undesirable heat transfer resulting in capacity loss and increased power consumption.

# 4.0 INSTALLATION

## 4.6 Initial Leak Testing

Indoor coils have only a holding charge of dry nitrogen. Keep all tube ends sealed until connections are to be made.

**⚠WARNING:** Do not use oxygen to purge lines or pressurize system for leak test. Oxygen reacts violently with oil, which can cause an explosion resulting in severe personal injury or death.

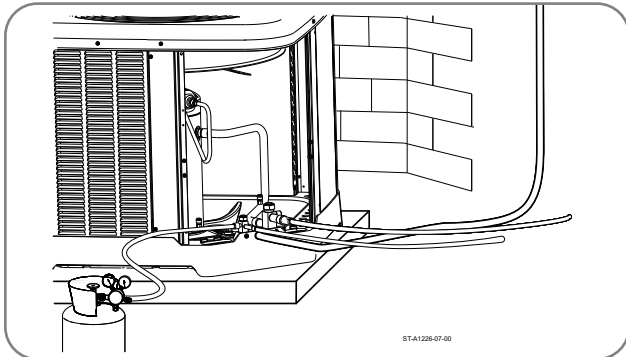

- Pressurize line set and coil through service fittings with dry nitrogen to 150 PSIG [1,034 kPa] (maximum). Close nitrogen tank valve, let system sit for at least 15 minutes, and check to see if the pressure has dropped. If the pressure has dropped, check for leaks at the line set braze joints with soap bubbles and repair leak as necessary. Repeat pressure test. If line set and coil hold pressure, proceed with line set and coil evacuation (see Sections 4.7 and 4.8 for evacuation and final leak testing).

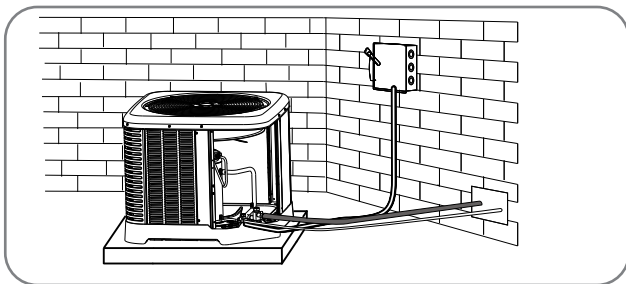

- The vapor line must be insulated for its entire length to prevent dripping (sweating) and prevent performance losses. Closed-cell foam insulation such as Armaflex and Rubatex® are satisfactory insulations for this purpose. Use 1/2" [12.7 mm] minimum insulation thickness. Additional insulation may be required for long runs. The liquid line must be insulated in any unconditioned space when long line sets are used and anytime the liquid line is run through an attic due to hot

temperatures that occur there.

## 4.7 Evacuation

Evacuation is one of the most important parts of the entire installation and service procedure. The life and efficiency of the equipment is dependent upon the thoroughness exercised by the serviceman when evacuating air and moisture from the system.

Air or nitrogen in the system increases condensing temperature and pressure, resulting in increased power consumption, erratic operation, and reduced capacity.

Moisture chemically reacts with the refrigerant and oil to form corrosive acid which attacks the compressor motor windings and internal parts and which can result in compressor failure.

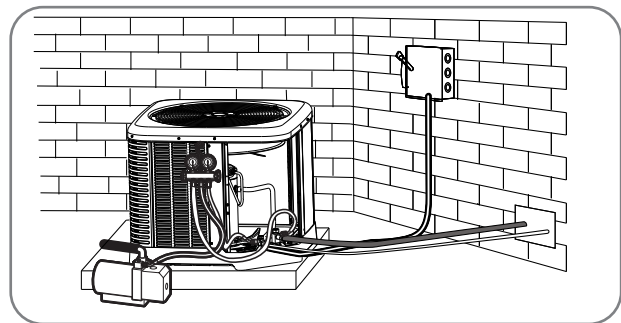

- After the system has been leak-checked and proven sealed, connect the vacuum pump and evacuate system to 500 microns and hold 500 microns or less for at least 15 minutes. The vacuum pump must be connected to both the high and low sides of the system by connecting to the two pressure ports. Use the largest size connections available since restrictive service connections may lead to false readings because of pressure drop through the fittings.

# 4.0 INSTALLATION

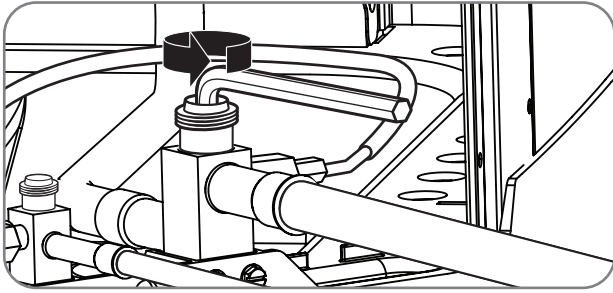

- After adequate evacuation, open both service valves by removing both brass service valve caps with an adjustable wrench. Insert a 3/16" [5 mm] or 5/16" [8 mm] hex wrench into the stem and turn counterclockwise until the wrench stops.

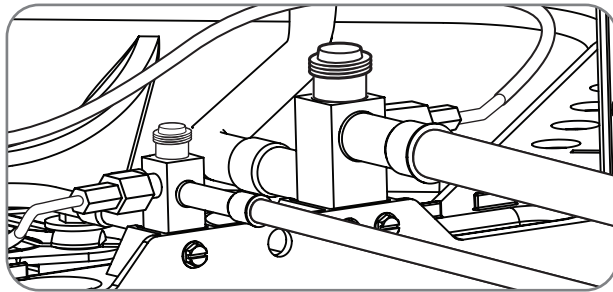

- If not already connected from evacuation process, gauges must be connected at this point to check and adjust charge.

**IMPORTANT:** Compressors should never be used to evacuate the air conditioning system because internal electrical arcing in near vacuum conditions may result in a damaged or failed compressor. Never run a scroll compressor while the system is in a vacuum or compressor failure will occur.

## 4.8 Final Leak Testing

After the unit has been properly evacuated and service valves opened, a halogen leak detector should be used to detect leaks in the system. All joints and piping within the outdoor unit, indoor coil, and interconnecting tubing should be checked for leaks. If a leak is detected, the refrigerant should be recovered before repairing the leak. The Clean Air Act prohibits releasing refrigerant into the atmosphere.

## 4.9 Control Wiring

**⚠WARNING:** Turn off electric power at the fuse box or service panel before making any electrical connections. Also, the ground connection must be completed before making line voltage connections. Failure to do so can result in electrical shock, severe personal injury, or death.

### 4.9.1 EcoNet™ Communications

The EcoNet™ enabled (-)A15AZ/(-)P16AZ/(-)A16AZ Series heat pumps and air conditioners are specifically designed to be matched with and EcoNet™ enabled air-handler or gas furnace and the EcoNet™ Control Center. While they are also designed to be controlled by a conventional 24VAC 2-stage thermostat, many features and benefits are lost.

### 4.9.2 EcoNet™ Control Center Installation

The EcoNet™ Control Center should be mounted 4 to 5 feet [1.2 to 1.5 m] above the floor on an inside wall of the living room or a hallway that has good air circulation from the other rooms being controlled by the Control Center. It is essential that there be free air circulation at the location of the same average temperature as other rooms being controlled. Movement of air should not be obstructed by furniture, doors, draperies, etc. The Control Center should not be mounted where it will be affected by drafts, hot or cold water pipes or air ducts in walls, radiant heat from fireplace, lamps, the sun, T.V. or an outside wall. See instructions packaged with Control Center for detailed mounting and installation instructions.

### 4.9.3 EcoNet™ Communication Wiring Connections

The four 18 AWG low-voltage control wires must be installed from the EcoNet™ Control Center to the indoor unit and from the indoor unit to the outdoor unit. The wire length between the Control Center and indoor unit should not be greater than 100 feet [30.5 m].

The wire length between the indoor unit and outdoor unit should not be greater than 125 feet [38.1 m].

Running low-voltage wires in conduit with line voltage power wires is not recommended. Low-voltage wiring must be connected to the low voltage terminal block on the Universal Outdoor Control. The terminal block can be unplugged from the control board to facilitate wiring.

An EcoNet™ communicating heat pump system consists of these matched components:

- EcoNet™ communicating outdoor unit.
- EcoNet™ communicating air handler or EcoNet™ communicating furnace.
- EcoNet™ Control Center.

# 4.0 INSTALLATION



## 4.9 Control Wiring (cont.)

**IMPORTANT:** The EcoNet™ control system requires continuous 18 AWG thermostat wire. **Do not use phone cord to connect indoor and outdoor units. This will damage the controls.**

The EcoNet™ control system requires four (4) control wires for unit operation:

- R 24 VAC
- C 24 VAC common
- Data wire E1 Communications
- Data wire E2 Communications

The EcoNet™ enabled air handler or furnace is equipped with a 24-volt, 40 or 50 VA transformer for proper system operation. See the wiring diagram below for low voltage wiring connections.

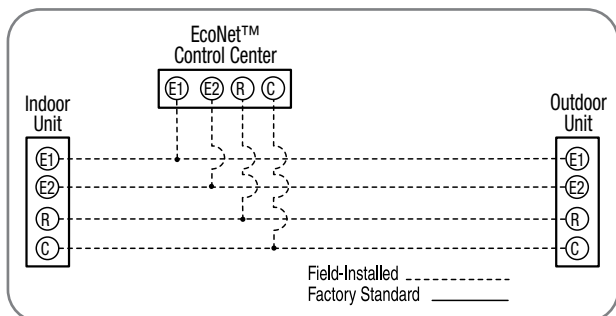

These wires need to be connected to each device (Control Center, indoor air handler or furnace, and outdoor unit).

Once all devices are connected, apply the line voltage to the indoor and outdoor units.

When all devices are powered, the EcoNet™ Control Center should detect the indoor and outdoor units within 45 seconds.

Once the system is powered and all components are communicating with each other, the airflow settings will be automatically configured in the air handler or furnace.

All adjustments for indoor airflow are made at the EcoNet™ Control Center from this point. Items that can be changed are airflow trim adjustment, on-demand dehumidification, cooling and heating airflow and electric heat airflow. The Control Center also has a wide range of fault and history information. To access any of the control center menus press the settings, status, or service icons at the bottom of the touch screen. Refer to the air handler or furnace installation manual and the EcoNet™ Control Center installation manual for further details on setting up the system and available adjustment options.

### 4.9.4 Conventional 24VAC Thermostat Control Wiring Connections

The (-)A15AZ/(-)P16AZ/(-)A16AZ series of outdoor units allow the installer to use a conventional 2-stage thermostat for limited unit operation.

**IMPORTANT:** The preferred method of unit installation and operation is by the *EcoNet™ Communicating System* which allows access to the fault history of the system. This diagnostic information is not available at the thermostat when the (-)A15AZ/(-)P16AZ/(-)A16AZ unit is using a conventional 2-stage thermostat.

Thermostat control wiring requires a minimum of six (6) wires for proper heatpump operation and four (5) wires for proper AC operation:

- R – 24 VAC (AC/HP)
- C – 24 VAC common (AC/HP)
- Y1 – Speed Command 1 (AC/HP)
- Y2 – Speed Command 2 (AC/HP)
- B – Heat pump operation (HP)
- W – Supplemental Heat During Defrost Cycle (AC/HP)

The following figures show the typical control wiring diagrams with (-)A15AZ/(-)A16AZ/(-)P16AZ heat pumps using a conventional two-stage 24VAC thermostat. Cooling and heating airflow levels will need to be adjusted for homeowner comfort once the system is operational.

WIRE COLOR CODE		
BK – BLACK	GY – GRAY	W – WHITE
BR – BROWN	O – ORANGE	Y – YELLOW
BL – BLUE	PR – PURPLE	
G – GREEN	R – RED	



# 4.0 INSTALLATION



## 4.9 Control Wiring (cont.)

### TYPICAL 2-STAGE THERMOSTAT: (-)P16 HEAT PUMP WITH AIR-HANDLER USING A THERMOSTAT WITH DEHUMIDIFICATION

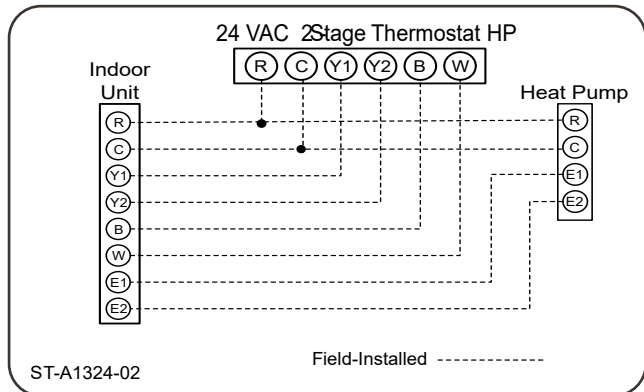

### TYPICAL 2-STAGE THERMOSTAT: AC WITH AIR-HANDLER

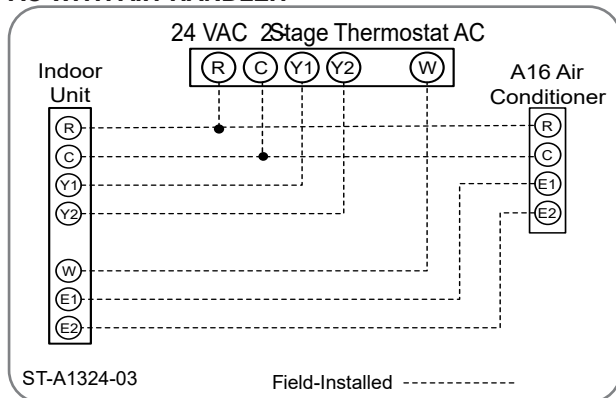

### 4.9.5 For Installations With Only 2 Thermostat Wires Between The Indoor And Outdoor Units.

Sourcing the following components and materials, use the provided wiring diagram to create an external 24VAC power supply to unit in the case that only two thermostat wires can be practically supplied from the indoor unit to the outdoor unit

Do not mount the new enclosure with the transformer to the outdoor unit. The enclosure with transformer must be mounted to the exterior wall of the home or structure or to a separate post or stand

Note that it is critical that the additional transformer is properly phased with the original transformer on the indoor unit.

To ensure this, measure "R" to earth or chassis ground on the indoor unit and make sure it measures 24VAC while "C" to chassis/earth ground is 0VAC. On the new outdoor transformer, with the transformer connected to the ODU thermostat terminal block, ensure that the low voltage lead connected to "R" on the thermostat terminal block of the unit measures 24VAC to earth/chassis ground while "C" on the same terminal block measures 0VAC to earth or chassis ground

To ensure this, measure "R" to earth or chassis ground on the indoor unit and make sure it measures 24VAC while "C" to chassis/earth ground is 0VAC. On the new outdoor transformer, with the transformer connected to the ODU thermostat terminal block, ensure that the low voltage lead connected to "R" on the thermostat terminal block of the unit measures 24VAC to earth/chassis ground while "C" on the same terminal block measures 0VAC to earth or chassis ground

**WARNING:** Never route low voltage (eg 24VAC thermostat) wiring in the same conduit or whip as line voltage (eg 120VAC, 240VAC and etc).

Install the fuse in the "R" circuit from the new transformer inside the new NEMA/IP enclosure (in the "R" wire before exiting the enclosure) with the transformer by crimping the 1/4" QC terminals to the wire and connecting those terminals directly to the legs of the fuse as shown in the photo below.

It is important that proper electrical power is available at the heat pump power terminal block. The acceptable operating voltage range is shown below.

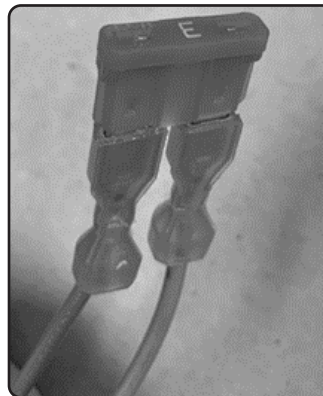



# 4.0 INSTALLATION



## 4.9 Control Wiring (cont.)

### Parts/Materials:

1. Minimum NEMA 3R or IP-65 rated, watertight electrical enclosure with integrated key, screw-down lid or padlock feature to prevent accidental access. Interior dimensions should be at least 2.5" x 3.5" x 3.5". (note: enclosures with Knock-out (KO) are preferred for simplification of installation). Same as, or similar to Grainger Item 3A909
2. A minimum 40VA (40W) (minimum), 240VAC to 24VAC (alternate 208VAC to 24VAC for 208VAC applications) Transformer Same as, or similar to Rheem part number 46-101905-01
3. Watertight conduit or electrical whips with watertight fittings/clamps (size and length as necessary) on each end. Two must be supplied; one for 240VAC wires and another for 24VAC wires.
4. 18GA wire with 2/64" Insulation rated for 600V (minimum), preferred colors;

- Brown (24VAC Common),
  - Red (24VAC SEC),
  - Black (240AC, L1),
  - Orange (240VAC L2)
- (all wire lengths will depend on installation)
5. 14GA wire with 2/64" Insulation rated for 600V (minimum), preferred colors:  
Green (ground) to disconnect or control box of outdoor unit  
(wire length will depend on installation)
  6. Appropriate mounting screws or bolts to mount transformer inside of NEMA/IP electrical enclosure.
  7. 3Amp ATC Style Fuse Same as, or similar to Grainger Item 2FCY5
  8. 1/4" 18GA insulated quick-connect (QC) terminals, QTY = 6 Same as, or Similar to Grainger Item 21DH01
  9. 14GA Ring Terminal, Qty = 1 Same as, or similar to Grainger Item 3VRU9

**Warning:** Never route low voltage (eg 24VAC thermostat) wiring in the same conduit or whip as line voltage (eg 120VAC, 240VAC and etc).

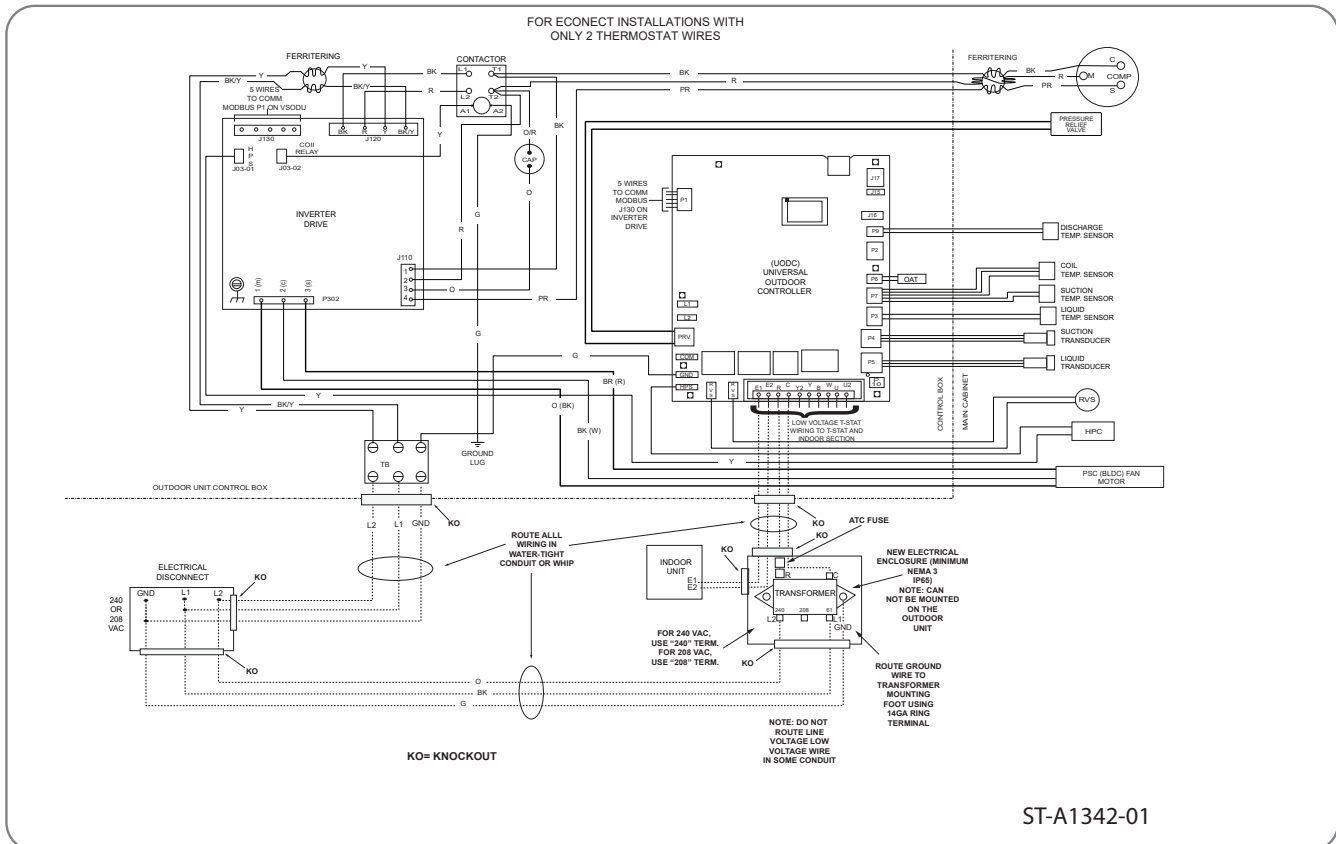

# 4.0 INSTALLATION



## 4.10 Power Wiring

It is important that proper electrical power is available at the heat pump power terminal block. The acceptable operating voltage range is shown below.

### VOLTAGE RANGES (60 HZ)

Nameplate Voltage	Operating Voltage Range at Maximum Load Conditions
208/230	197–253

Install a branch circuit disconnect within sight of the unit and of adequate size to handle the minimum circuit ampacity (MCA) current (see “Electrical Data” in Section 3.2).

Field wiring must comply with the National Electric Code (C.E.C. in Canada) and any applicable local code.

Power wiring must be run in a rain-tight conduit. Conduit must be attached to the hole in the bottom of the control box.

Connect power wiring to line-voltage lugs on the terminal block located in the outdoor heat pump unit electrical box. (See wiring diagram attached to unit access panel.)

Check all electrical connections, including factory wiring within the unit and make sure all connections are tight.

**DO NOT** connect aluminum field wire to the line voltage terminal block.

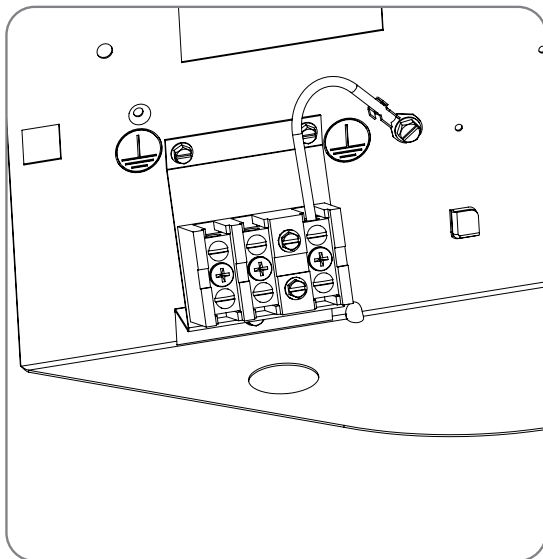

## 4.11 Grounding

**⚠ WARNING:** The unit must be permanently grounded. Failure to do so can cause electrical shock resulting in severe personal injury or death.

A ground lug is provided near the line-voltage power entrance for a ground wire.

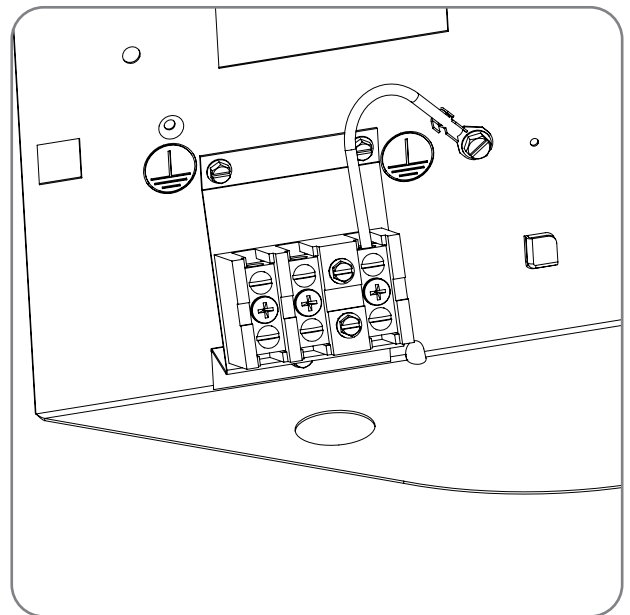

# 5.0 SYSTEM START-UP AND REFRIGERANT CHARGING

## 5.1 System Start-Up Overview

Once the system hardware and wiring has been properly installed, the next step is to start the system up, verify indoor air-flow, and adjust the refrigerant charge. To assure optimum comfort, efficiency, and reliability, it is extremely important to follow the procedures in this section to assure the indoor air-flow and refrigerant charge are correct.

## 5.2 Initial Power-Up and EcoNet™ Communication Verification

After all installation steps have been completed, apply electrical power to the indoor and outdoor units. The EcoNet™ Control Center or thermostat should be switched to the off position initially. Within 45 seconds of power being applied, the EcoNet™ Control Center should detect the indoor and outdoor units.

**IMPORTANT:** It is recommended to wait at least 12 hours after electrical power is applied to the outdoor unit before starting the compressor to assure any liquid refrigerant inside the compressor has been driven out by the compressor stator heat.

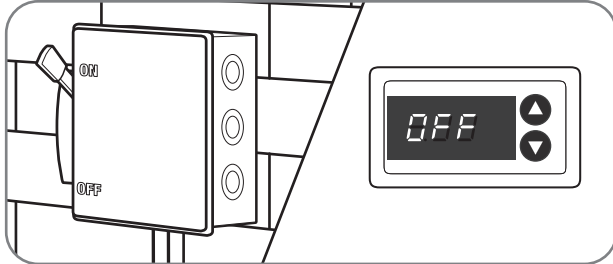

## 5.3 EcoNet™ Control Center Set-Up

Follow the set-up instructions included with the EcoNet™ Control Center prior to starting system. Cooling dehumidification must be disabled for indoor air-flow verification and refrigerant charging. The indoor air-flow trim adjustment should be set to 0% for indoor air-flow verification, but should be adjusted prior to refrigerant charging should the application require an adjustment to the indoor air-flow.

## 5.4 Initial System Start-Up

Using the EcoNet™ Control Center service menu (See Section 5.5 below) or using the thermostat (See Section 5.6 below), put the system into the charging mode which will force it to operate at 100% capacity and indoor air-flow which is necessary for accurate indoor air-flow verification and refrigerant charging. Check to make sure "On-Demand Dehumidification" is turned off in the EcoNet™ Control Center (or on the air-handler or gas furnace control board for conventional 24VAC control applications).

Wiring

Start-Up

# 5.0 SYSTEM START-UP AND REFRIGERANT CHARGING

## 5.5 Entering Charge Mode Using EcoNet™ Control Center Service Menu

1. Set the "Mode" to the "OFF" position.
2. Select "SERVICE" on the EcoNet™ Control Center screen.
3. Select "ODU Checkout". If the next screen displays a flashing "Lock-Out" message, there will be up to a 5 minute delay before it is possible to continue.
4. Once the flashing lock-out message disappears, touch OFF on the screen displayed to the right of "Var Speed ODU Test".
5. Touch the "UP" arrow repeatedly until the "Heat Charge" or "Cool Charge" menu item is displayed depending on which mode the system is to be charged in.
6. Touch "Start Test".
7. System will now operate at 100% of capacity and indoor air-flow to allow proper indoor air-flow verification and refrigerant charging until the Charge Mode is manually ended. There may be a delay before the system actually starts. If the system doesn't start, cycle power to both the indoor and outdoor units and repeat steps 1-6.
8. **Note:** When charging in the heating mode, the system will initiate a defrost cycle every 34 minutes if the coil temperature is below 35°F [1.7°C] to assure the coil stays frost free during the charging process. Allow the system to complete the defrost cycle and stabilize for at least 10 minutes before attempting to evaluate the charge level.
9. To end Charge Mode, touch the "UP" arrow repeatedly until "OFF" is displayed on the screen and then touch "Stop Test". Then touch the left arrow on the screen to return to the main screen.
10. If the indoor blower continues to run continuously after exiting the Charge Mode, cycle the power to the air-handler or furnace.

## 5.6 Entering Charge Mode When Using a Universal Outdoor Control

1. Set the thermostat to the cool or heat mode depending on which mode the system is to be charged in.
2. Adjust the set point several degrees below (cool mode) or above (heat mode) the room temperature to assure the thermostat is calling for operation and will continue to do so throughout the charging process.
3. When the charging process is complete, adjust the temperature set-point to the desired level.

# 5.0 SYSTEM START-UP AND REFRIGERANT CHARGING

## 5.7 Indoor Air-Flow Verification

Correct indoor air-flow and proper supply air distribution is critical to system comfort, efficiency and reliability. Excessive indoor air-flow results in elevated humidity levels in the cooling mode and excessive air noise. Low indoor air-flow reduces system capacity and can result in coil icing and compressor failure in the cooling mode and can cause nuisance high pressure switch tripping and increases power consumption in the heating mode.

Fortunately, when the (-)A15AZ/(-)P16AZ/(-)A16AZ outdoor unit are matched to the correct air-handler or furnace/coil combination and are controlled by the communication EcoNet™ Control Center, the indoor air-flow is automatically controlled to the proper level based on the model data stored in the UODC. When the indoor blower is operating, the EcoNet™ Control Center will display the indoor air-flow in the Service Menu of the control. The approximate indoor air-flow is also displayed in 100 CFM [47 l/s] increments by a flashing LED on

the air-handler or furnace control board while the blower is operating (one flash per 100 CFM [47 l/s]) for installations where a conventional 24VAC thermostat is used.

Once the system is operating in the Charging Mode, confirm the indoor air-flow is close to those values in the table below. If the displayed indoor air-flow is not reasonably close to the value in the table, confirm cooling dehumidification is disabled, the indoor air-flow trim adjustment is set to 0%, and verify the model numbers of the indoor and outdoor units are an approved combination by the manufacturer. Once the indoor air-flow is verified, the indoor air-flow trim adjustment may be changed to suit the installation and should be done prior to final charge adjustment.

**NOTICE:** AHRI rated indoor air-flow may differ slightly from values in the table below.  
**NOTE:** All indoor air-flow trims must be adjusted using the bluetooth contractor's app.

Outdoor Unit Model No.	Displayed Indoor CFM Cooling Mode	Displayed Indoor CFM Heating Mode
(-)P16AZ24/(-)A16AZ24/(-)A15AZ24	750	750
(-)P16AZ36/(-)A16AZ36/(-)A15AZ36	1125	1125
(-)P16AZ48/(-)A16AZ48/(-)A15AZ48	1450	1450
(-)P16AZ60/(-)A16AZ60/(-)A15AZ60	1800	1800

## 5.8 Refrigerant Charging

The refrigerant charge for all systems should be checked against the Charging Chart located inside the access panel cover.

**⚠ WARNING:** The top of the scroll compressor shell is hot. Touching the compressor top may result in serious personal injury.

**⚠ CAUTION:** R-410A pressures are approximately 60% higher (1.6 times) than R-22 pressures. Use appropriate care when using this refrigerant. Failure to exercise care may result in equipment damage or personal injury.

Charge for all systems should be checked against the Charging Chart inside the access panel cover.

**IMPORTANT:** Do not operate the compressor without charge in the system.

Addition of R-410A will raise high-side pressures (liquid and discharge).

**NOTICE:** System maintenance is to be performed by a qualified and certified technician.

The optimum refrigerant charge for any outdoor unit matched with an indoor coil/air handler is affected by the application. Therefore, charging data has been developed to assist the field technician in optimizing the charge for all mounting configurations (UF – Upflow, DF – Downflow, LH – Left-Hand Discharge, and RH – Right-Hand Discharge). Refer to the charging chart inside the access panel cover on the unit and choose the appropriate column for the specific application being installed or serviced. New installations utilizing either an RCF indoor coil installed on a gas furnace, RH3VZ or an RHMVZ series air handler in the downflow or horizontal right-hand discharge may require removal of some refrigerant since the factory charge could result in an overcharge condition for short line length applications.

The following method is used for charging systems in the cooling and heating mode. All steps listed should be performed to ensure proper charge has been set. For measuring pressures, the service valve port on the liquid valve (small valve) and the true service port located between the two service valves are to be used.

# 5.0 SYSTEM START-UP AND REFRIGERANT CHARGING

## 5.8.1 Measurement Device Set-Up

1. With an R-410A gauge set, attach the high-pressure hose to the access fitting on the liquid line (small service valve at the OD unit).
2. Attach the low-pressure hose to the exterior suction port located between the two service valves that is connected to the suction tube between the reversing valve and compressor.
3. Attach a temperature probe within 6" [15.2 cm] of the outside of the unit on the copper liquid line (small line). For more accurate measurements, clean the copper line prior to measurement and use a calibrated clamp-on temperature probe or an insulated surface thermocouple.

## 5.8.2 Preliminary Charging by Weight

**NOTICE:** Adjust the system charge by weight for the linear length of the refrigerant line set.

For a new installation, evacuation of inter-connecting tubing and indoor coil is adequate; otherwise, evacuate the entire system. Use the factory charge shown in "Electrical and Physical Data" in Section 3.2 of these instructions or on the unit data plate. Note that the charge value includes charge required for 15 ft. [4.6 m] of standard-size liquid line without a filter drier.

Calculate actual charge required with the actual installed liquid line size and length using:

1/4" [6.4 mm] O.D. = .3 oz./ft. [28.3 g/m]

5/16" [7.9 mm] O.D. = .4 oz./ft. [37.7 g/m]

3/8" [9.5 mm] O.D. = .6 oz./ft. [56.7 g/m]

1/2" [12.7 mm] O.D. = 1.2 oz./ft. [113.3 g/m]

Add 6 oz. [170 g] for field-installed filter drier.

**Charge Adjustment = (Line Set (oz./ft.) x Total Length) – Factory Charge for Line Set**

**Example:** A three ton heat pump unit with factory installed 3/8" liquid service valve requires 75 ft. of line set with a liquid line diameter of 1/2".

**Factory Charge for Line Set** = 15 ft. x .6 oz. = 9 oz.

**Charge Adjustment** = (1.2 oz. x 75 ft.) – 9 oz. = + 81 oz.

With an accurate scale (+/- 1 oz. [28.3 g]) or volumetric charging device, adjust the refrigerant charge based on the actual line set length. If the entire system has been evacuated, add the total calculated charge.

**IMPORTANT:** Charging by weight is not always accurate since the application can affect the optimum refrigerant charge. Charging by weight is considered a starting point ONLY. Always check the charge by using the Charging Chart and adjust as necessary. CHARGING BY LIQUID SUBCOOLING PER THE SYSTEM CHARGING CHART MUST BE

USED FOR FINAL CHARGE ADJUSTMENT.

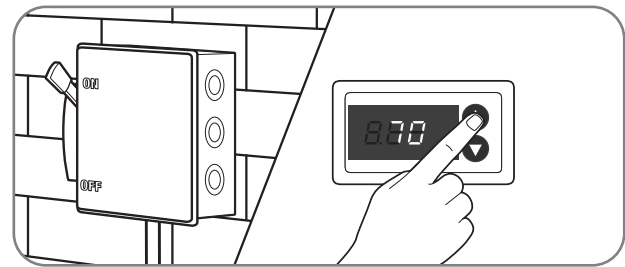

**IMPORTANT:** R-410A is a blended refrigerant of R-32 and R-125 (50/50). These two refrigerants have different saturation curves and therefore change state at different pressures and temperatures. If charge is added to the system in the vapor state, it is possible to have a disproportionate amount of each part of the R-410A blend which will cause unstable and inefficient operation. Therefore, it is critical to add R-410A in the liquid form only!

## 5.8.3 Preliminary Charging by Pressures (Optional)

1. Following airflow verification and charge weigh-in, run the unit for a minimum of 15 minutes prior to noting pressures and temperatures.

**IMPORTANT:** Indoor conditions as measured at the indoor coil must be within 2°F [1.1°C] of comfort conditions per the homeowner's preference.

**NOTICE:** If the indoor temperature is above or below this range, run the system to bring the temperature down or run the electric heat/furnace to bring the temperature up to within this range.

2. Note the Outdoor Dry Bulb Temperature, ODDB° = \_\_\_\_\_°F [°C]. Unit charging is recommended under the following outdoor conditions ONLY:

Cooling Mode ONLY: 55°F [12.8°C] outdoor dry bulb and above

Heating Mode ONLY: Between 40°F [4.4°C] and 60°F [15.6°C] outdoor dry bulb

3. Locate and note the design pressures. The correct liquid and vapor pressures are found at the intersection of the installed system and the outdoor ambient temperature on the Charging Chart located inside the access panel cover.

Liquid Pressure: = \_\_\_\_\_psig [kPa]; Vapor Pressure = \_\_\_\_\_psig [kPa]

**NOTICE:** The refrigerant pressures provided are for preliminary charge check ONLY. These pressure values are typical, but may vary due to application. Evaporator load (indoor coil in cooling mode/outdoor coil in heating mode) will cause pressures to deviate. The values listed are for the correct matched indoor coil



# 5.0 SYSTEM START-UP AND REFRIGERANT CHARGING

ONLY!

- If the measured liquid pressure is below the listed requirement for the given outdoor and indoor conditions, add charge. If the measured liquid pressure is above the listed requirement for the given outdoor and indoor conditions, remove charge.

## 5.8.4 Final Charging by Liquid Subcooling

- After preliminary charging by weight or pressures, find the design subcooling value. The correct subcooling value is found at the intersection of the installed system and the outdoor ambient temperature on the Charging Chart located inside the access panel cover.

SC° from Charging Chart = \_\_\_\_\_ °F [°C].

**IMPORTANT:** Indoor conditions as measured at the indoor coil are required to be within 2°F (1.1°C) of comfort conditions as preferred by the homeowner and must have operated for at least 15 minutes prior to final charge adjustment. Unit charging is recommended under the following outdoor conditions ONLY:

Cooling Mode: 55°F [12.8°C] outdoor dry bulb and above

Heating Mode: Between 40°F [4.4°C] and 60°F [15.6°C] outdoor dry bulb

**NOTICE:** Systems should not be charged below 40°F [4.4°C] outdoor temperature.

**NOTICE:** If the indoor temperature is above or below the recommended range, run the system to bring the temperature down or run the electric heat/furnace to bring the temperature up.

- Note the measured Liquid Pressure, Liq Press = \_\_\_\_\_ psig [kPa], as measured from the liquid (small) service valve. Use the Temperature Pressure Chart below to note the corresponding

saturation temperature for R-410A at the measured liquid pressure.

Liquid Saturation Temperature, SAT° = \_\_\_\_\_ °F [°C].

- Note the liquid line temperature, Liq° = \_\_\_\_\_ °F [°C], as measured from a temperature probe located within 6" [15.2 cm] outside of the unit on the copper liquid line (small line). It is recommended to use a calibrated clamp-on temperature probe or an insulated surface thermocouple.
- Subtract the liquid line temperature from the saturation temperature to calculate subcooling. SAT° \_\_\_\_\_ °F [°C] - Liq° \_\_\_\_\_ °F [°C] = SC° \_\_\_\_\_ °F [°C]
- Adjust charge to obtain the specified subcooling value. If the measured subcooling level is below the listed requirement for the given outdoor temperature, add charge. If the measured subcooling level is above the listed requirement for the given outdoor temperature, remove charge.

## 5.9 Completing Installation

- Disconnect the hoses from the pressure ports. Replace the pressure port caps and tighten adequately to seal caps. **DO NOT overtighten.**
- Replace the service valve top caps finger-tight and then tighten with a wrench to adequately seal caps. **DO NOT overtighten.**
- Replace control box cover and service panel and install screws to secure panels.
- Restore power to unit at disconnect if required.
- Exit Charging Mode and configure EcoNet™ Control Center or thermostat per the thermostat installation instructions and set to desired mode and temperature.

### 5.8.5 R-410A Temperature Pressure Chart

SATURATION TEMP °F [°C]	R-410A PSIG [kPa]	SATURATION TEMP °F [°C]	R-410A PSIG [kPa]	SATURATION TEMP °F [°C]	R-410A PSIG [kPa]	SATURATION TEMP °F [°C]	R-410A PSIG [kPa]
-150 [-101]	-	-30 [-34]	17.9 [123.4]	35 [2]	107.5 [741.2]	100 [38]	317.4 [2188.4]
-140 [-96]	-	-25 [-32]	22.0 [151.7]	40 [4]	118.5 [817.0]	105 [41]	340.6 [2348.4]
-130 [-90]	-	-20 [-29]	26.4 [182.0]	45 [7]	130.2 [897.7]	110 [43]	365.1 [2517.3]
-120 [-84]	-	-15 [-26]	31.3 [215.8]	50 [10]	142.7 [983.9]	115 [46]	390.9 [2695.2]
-110 [-79]	-	-10 [-23]	36.5 [251.7]	55 [13]	156.0 [1075.6]	120 [49]	418.0 [2882.0]
-100 [-73]	-	-5 [-21]	42.2 [291.0]	60 [16]	170.1 [1172.8]	125 [52]	446.5 [3078.5]
-90 [-68]	-	0 [-18]	48.4 [333.7]	65 [18]	185.1 [1276.2]	130 [54]	476.5 [3285.4]
-80 [-62]	-	5 [-15]	55.1 [380.0]	70 [21]	201.0 [1385.8]	135 [57]	508.0 [3502.5]
-70 [-57]	-	10 [-12]	62.4 [430.2]	75 [24]	217.8 [1501.7]	140 [60]	541.2 [3731.4]
-60 [-51]	0.4 [2.8]	15 [-9]	70.2 [484.0]	80 [27]	235.6 [1624.4]	145 [63]	576.0 [3971.4]
-50 [-46]	5.1 [35.2]	20 [-7]	78.5 [541.2]	85 [29]	254.5 [1754.7]	150 [66]	612.8 [4225.1]
-40 [-40]	10.9 [75.2]	25 [-4]	87.5 [603.3]	90 [32]	274.3 [1891.2]		
-35 [-37]	14.2 [97.9]	30 [-1]	97.2 [670.2]	95 [35]	295.3 [2036.0]		

# 6.0 NORMAL SEQUENCE OF OPERATION

The following sections provide details on how the (-)A15AZ/(-)P16AZ/(-)A16AZ outdoor systems are designed to operate under normal conditions. Under abnormal conditions, Active Compressor and Inverter Protection features built into the controls may alter how the system operates to protect the compressor and inverter from damage. The sequence of operation is based on the system being set up for EcoNet™ communications using an EcoNet™ enabled air-handler or gas furnace and an EcoNet™ Control Center. A section is provided at the end that describes how the system will operate if a conventional 24VAC 2-stage thermostat is used.

**NOTE: The use of a conventional 24VAC thermostat eliminates many of the advanced operating and diagnostic features the customer has paid for and is strongly discouraged.**

## 6.1 Cooling Mode

The (-)A15AZ/(-)P16AZ/(-)A16AZ unit will have variable capacity from 45% to 65%. A compressor demand above 65% capacity shall switch the inverter operation to line voltage. This type of hybrid operation shall either take place in a fully communicating system or when connected to a communicating indoor unit and a non-communicating thermostat. In communicating mode, the control center shall send the compressor demand and shall decide when the inverter runs at line voltage or at variable speed capacity.

**Note: In legacy mode the outdoor control shall determine the compressor speed.**

The percentage of capacity required is based on the difference between the temperature set-point and the room temperature measured at the Control Center. One second after the compressor starts, the UODC will direct the variable speed outdoor motor to operate at the appropriate speed to deliver the necessary outdoor air-flow for that capacity percentage. Upon a call for cooling/heating, the EcoNet™ Control Center accesses the indoor air-flow parameters found in the model data residing in the UODC and directs the EcoNet™ enabled air-handler or gas furnace control board to deliver an appropriate indoor air-flow level based on the capacity percentage required at that point in time. The EcoNet™ air-handler or gas furnace control board will then direct the variable speed indoor blower motor to start and operate at the requested cooling/heating air-flow level. As the building load changes throughout the call for cooling/heating operation, the compressor speed, outdoor fan speed, and indoor air-flow level will respond by ramping up or down as required to meet the building load exactly rather than simply cycling on and off as conventional systems do. When the call for cooling/heating has ended, the EcoNet™ Control Center will

direct the outdoor and indoor units to shut down. The compressor and outdoor fan motor will ramp down to zero RPM and the indoor blower motor will ramp down to the minimum air-flow level for 30-45 seconds to extract the residual heating from the cold indoor coil before it stops.

**Note: Anytime the compressor goes to line operation, the unit shall stay there until the heating/cooling satisfies the thermostat demand**

## 6.2 On-Demand Cooling Dehumidification

The EcoNet™ Control Center can be configured for On-Demand Dehumidification. This feature allows the system to automatically increase the level of dehumidification in the cooling mode by decreasing the indoor air-flow by 15% when the indoor relative humidity measured at the Control Center rises above the set-point. Once the relative humidity drops to or below the set-point, the indoor air-flow level returns to normal.

## 6.3 Low Ambient Cooling Mode

In some installations, a requirement exists for cooling a controlled air space when the outdoor ambient is below the normal range for cooling such as a computer room or other enclosed areas where a large heat load exists that must be kept cool. Low ambient cooling is a special cooling mode that allows the unit to provide cooling when the outdoor temperature is below low ambient temperature. When necessary, the outdoor fan shall be cycled off to maintain liquid pressure in the system. Operation below low ambient temperature requires special interpretation of the state of the suction pressure. If the outdoor air temperature is less than the low ambient temperature, a flag shall be set and the low ambient cooling algorithm shall run. If the outdoor temperature rises one degree above the low ambient temperature, the low ambient cooling algorithm shall turn off and the flag shall be reset.

**Note: This mode shall not be active if any sensor error code is active.**

## 6.4 Supplemental Electric Heat in Heating Mode

If the building load should exceed the heating capacity in extreme outdoor conditions, the EcoNet™ Control Center or 24 VAC 2-stage thermostat will direct the RH3VZ or RHMVZ air-handler to energize supplemental electric heat as required to meet the building load. The indoor air-flow will be forced to operate at the maximum level for the system. For 13kW heaters and higher, the supplemental electric

# 6.0 NORMAL SEQUENCE OF OPERATION

heat will be energized in two stages as required. The compressor and outdoor fan will continue to operate at maximum capacity while supplemental electric heat is energized.

## 6.5 Dual Fuel Applications – Heating Mode

If the building load should exceed the heat pump heating capacity in extreme outdoor conditions, the EcoNet™ Control Center will direct the outdoor unit to shut down and heating responsibility will be transferred to the gas furnace. An outdoor ambient temperature can be set in the EcoNet™ Control Center to direct the system to automatically switch to gas heat when the outdoor ambient temperature drops below that set-point. If the EcoNet™ Control Center is set to the EMERGENCY HEAT (Furnace Only) mode, heating responsibility will be transferred to the gas furnace.

## 6.6 Demand Defrost

Defrosting of the outdoor coil in the heating mode is controlled by the Universal Outdoor Control (UODC). (-)P16AZ heat pumps utilizes “demand defrost” that initiates a defrost cycle only when frosting is detected on the outdoor coil during heating operation. The UODC continuously monitors the Outdoor Ambient Temperature Thermistor (OAT) and Outdoor Coil Temperature Thermistor to determine when a defrost cycle is required. The following sequence is followed for defrost cycles.

- **Defrost Initiation:** A defrost cycle is initiated when the following conditions are met.
  1. The outdoor coil temperature is below 35°F [1.7°C].
  2. The compressor has operated for at least 34 minutes with the outdoor coil temperature below 35°F [1.7°C].
  3. The UODC determines a defrost cycle is required based on the OAT and EVAPIN temperatures.

If the above conditions are met, the following action will be taken.

1. The compressor speed is ramped to the predetermined reversing valve switching speed for 30 seconds before the reversing valve is de-energized.
2. The reversing valve is de-energized which will cause it to shift to the cooling position.

**Note: If the demand for defrost is initiated while on the drive the unit will remain on the drive until the defrost cycle is complete. If the demand for the defrost is initiated while**

**on line voltage then the unit will remain on line voltage until the defrost cycle is complete.**

4. The indoor air-handler or gas furnace is directed to supply supplemental heat to prevent cold air from being discharged from the supply registers during the defrost cycle.
  5. The compressor speed is ramped to the pre-determined defrost speed for the duration of the defrost cycle.
- **Defrost Termination:** The defrost cycle will continue until the coil temperature has reached the termination temperature or 14 minutes have elapsed, whichever comes first. The factory default termination temperature is 60°F [15.6°C]. When the coil temperature reaches the termination temperature or 14 minutes have elapsed, the following action is taken.
    1. The compressor speed is ramped to the reversing valve switching speed for 30 seconds before the reversing valve is energized.
    2. The reversing valve will be energized, switching it back to the heating position.
    3. The outdoor fan motor is energized.
    4. Auxiliary heat is de-energized.
    5. The compressor speed will ramp to a pre-determined oil circulation speed for 6 minutes.
    6. The system returns to normal heating operation as directed by the EcoNet™ Control Center.

**NOTE: Should the outdoor ambient temperature thermistor fail, the UODC will initiate a defrost every 34 minutes of operation when the coil temperature is below 35°F.**

# 6.0 NORMAL SEQUENCE OF OPERATION

Switch 1	Switch 2	Coil Temperature at Defrost Termination
Off	Off	60°F [15.6°C]
On	Off	50°F [10°C]
Off	On	40°F [4.4°C]
On	On	70°F [21.1°C]

## 6.7 Sequence of Operation for Conventional 2-Stage 24VAC Thermostat Controls

The (-)A15AZ/(-)P16AZ/(-)A16AZ unit will have variable capacity from 45% to 65%. A compressor demand above 65% capacity shall switch the inverter operation to line voltage. This type of hybrid operation shall either take place when connected to a communicating indoor unit and a non-communicating thermostat.

In legacy mode, the outdoor control shall determine the compressor speed.

The difference between the temperature set-point and the room temperature measured at the 24VAC 2-stage thermostat will determine whether the system gets a cooling or heating call. Upon a cooling/heating call, the UODC will command the air-handler or gas furnace control board to deliver an appropriate indoor air-flow level based on the capacity using the parameters stored internally to the UODC. One second after the compressor starts, the UODC will direct the variable speed outdoor motor to operate at the appropriate speed to deliver the necessary outdoor air-flow for that capacity based on the parameters stored in the UODC. As the building load changes throughout the call for cooling/heating operation, the compressor speed, outdoor fan speed, and indoor air-flow level will respond by ramping up or down as required to meet the building load exactly rather than simply cycling on and off as conventional systems do. When the call for cooling/heating has ended, the call from the 2-stage thermostat will be removed and the UODC will direct the outdoor and indoor units to shut down. The compressor and outdoor fan motor will ramp down to zero RPM and the indoor blower motor will ramp down to the minimum air-flow level for 30-45 seconds to extract the residual heating from the cold indoor coil before it stops.

**Note: Anytime the compressor goes to line operation, the unit shall stay there until the heating/cooling satisfies the thermostat demand**

# 7.0 COMPONENTS & CONTROLS



## 7.1 EcoNet™ Universal Outdoor Control (UODC)

### 7.1.1 Board Features and Connections

(-)A15AZ/(-)P16AZ/(-)A16AZ outdoor units are equipped with a Universal Outdoor Control (UODC) that interfaces with the inverter, EcoNet™ Control Center, and EcoNet™ enabled air-handler or gas furnace using the EcoNet™ serial communication protocol. The UODC provides a low voltage terminal block for control wiring and connections for various sensors, controls, outdoor fan motor and inverter. If an alert or alarm occurs the Econet Control Center will display the active faults as well as fault history. If used with the conventional 24 VAC 2-stage thermostat then these faults can be found using the Bluetooth Contractor's App. Buttons are provided to initiate and terminate various test modes. A plug-in memory card provides model specific information (model data) necessary for proper

The following is a list of features on the UODC and location of each.

1. Bluetooth
2. Discharge Temp

3. EXV
4. OAT
5. COIL/OST
6. OLT/CPT
7. Suction Pressure Tranducer
8. Liquid Pressure Tranducer
9. Reversing Valve
10. HPS
11. Common
12. Pressure Relief Valve
13. ModBus
14. SW1 and SW2
15. Power Supply LED
16. Fault Code LED
17. CPU Status LED
18. Heating Status LED
19. Cooling Status LED
20. Bluetooth LED

**CAUTION:** UNIT MAY START SUDDENLY AND WITHOUT WARNING.

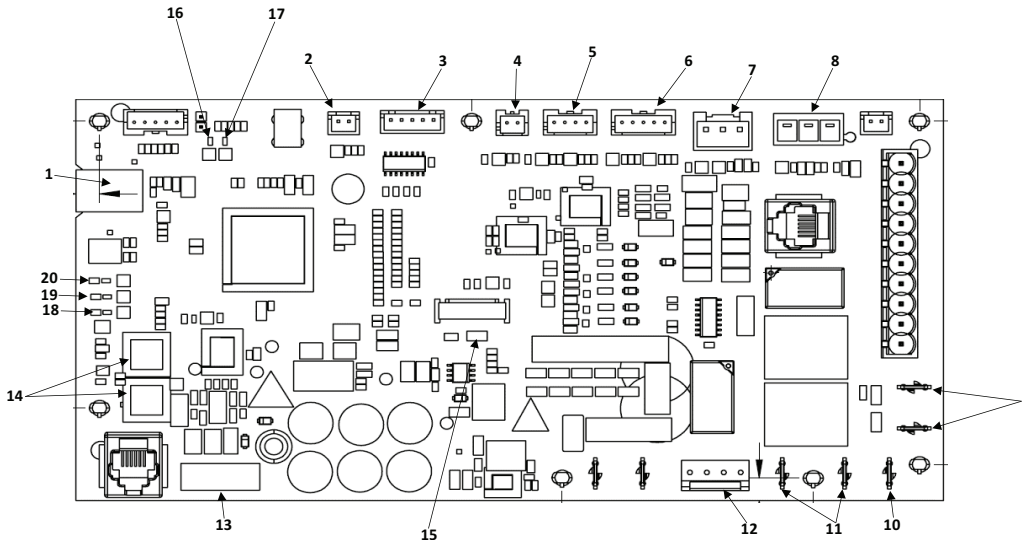

ST-A1324-04

### 7.1.2 Factory Superheat Setting

The UODC is pre-programmed with the optimum superheat setting of 6° for each outdoor unit.



# 7.0 COMPONENTS & CONTROLS

## 7.2 Power Inverter Compressor Control

(-)A15AZ/(-)P16AZ/(-)A16AZ outdoor units are equipped with a power inverter that varies the compressor speed to match the changing capacity needs of the conditioned space. The inverter interfaces with the Universal Outdoor Control (UODC) which communicates the level of system capacity that is required to the inverter based on input from the EcoNet™ Control Center or conventional 24VAC 2-stage thermostat. The inverter converts incoming single phase power to simulated variable frequency 3-phase power that is connected to the 3-phase compressor motor. Each of the four (-)P20 models has a unique inverter specifically designed and qualified for that specific model to provide reliable operation under the most extreme conditions. Each inverter is programmed to monitor compressor power consumption, motor torque, input current, input voltage,

compressor discharge pressure, and compressor discharge temperature. When the inverter identifies a condition that could potentially result in compressor or inverter damage, it automatically reduces the compressor speed until a more reliable operating condition is obtained or shuts the compressor completely off if necessary. Once safe operating conditions are attained, the inverter will gradually increase the compressor speed in an attempt to meet the capacity demand as long as the operating conditions remain within the safe operating range of the compressor and inverter.

1. RS485 Communication
2. Input Power
3. Drive Output
4. OD Fan Motor

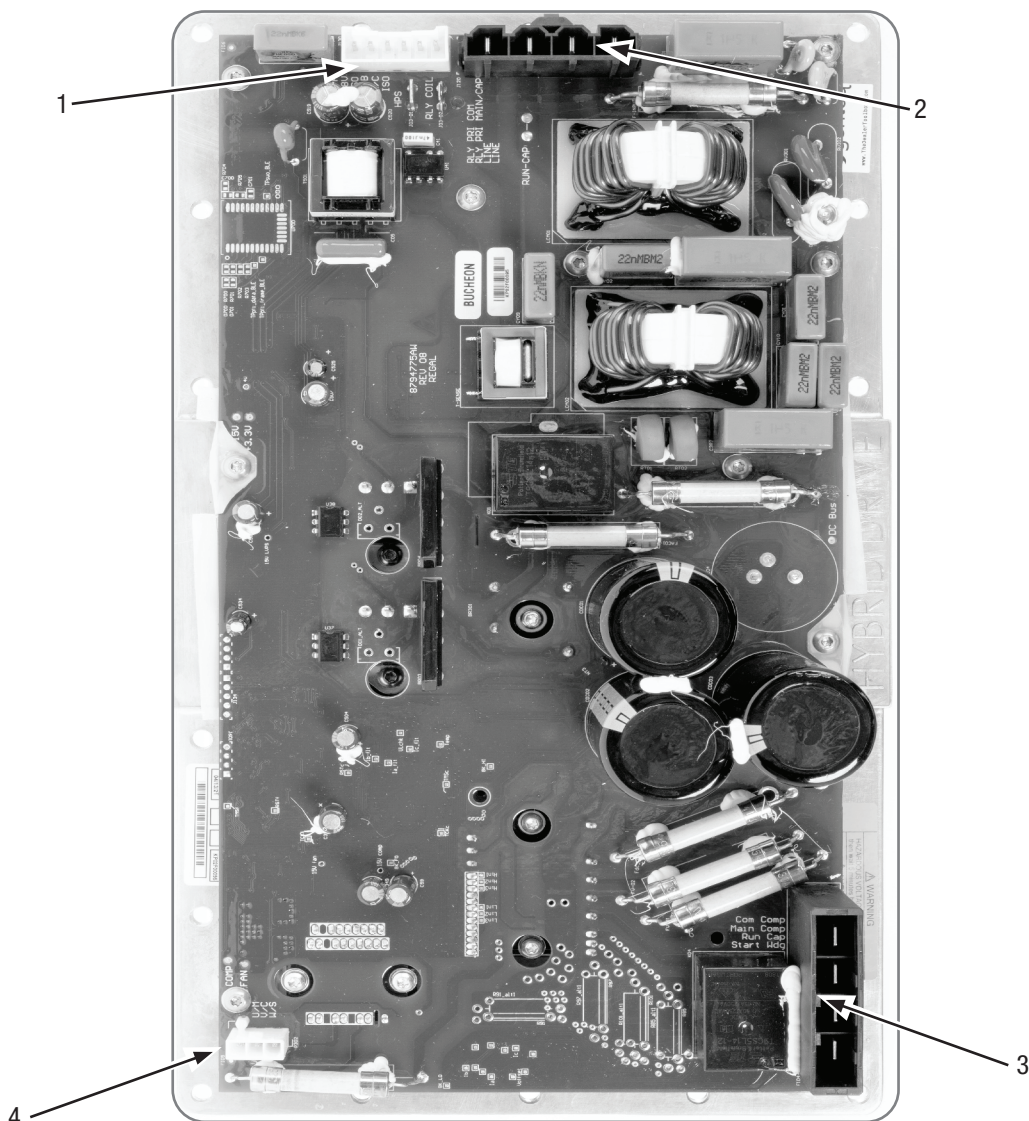



# 8.0 ACTIVE SYSTEM PROTECTION FEATURES

The controls found in the (-)A15AZ/(-)P16AZ/(-)A16AZ outdoor units are designed to prevent the system from operating in under conditions that could be harmful to the compressor and inverter. The Universal Outdoor Control (UODC) and Power Inverter continuously monitor multiple sensors, current, and voltage and will modify the compressor speed or completely shut the system down to protect the compressor and/or inverter if harmful operating conditions are sensed. This process is called Active System Protection. Sections 8.1 – 8.14 give a brief description of the different forms of protection that are provided. Refer to the Econet help pages on the Rheem website for further troubleshooting and diagnostics.

## 8.1 Minimum Run Timer

A minimum run time of 5 minutes is maintained by the VSODC to minimize short cycling which can be harmful to the compressor.

## 8.2 Oil Return Cycle

When the system has been operating at significantly reduced capacity for an extended period of time, the Universal Outdoor Control (UODC) will signal the Inverter to speed the compressor up to 70% capacity to help bring any oil that has accumulated in the indoor coil and refrigerant lines back to the compressor sump.

## 8.3 High Discharge Temperature

The Power Inverter continuously monitors the Discharge Line Thermistor input to protect the compressor should the discharge temperature reach an unsafe level. If the discharge line temperature rises to 235°F [113°C], the Inverter will reduce the compressor RPM incrementally until the temperature drops to 200°F [93°C]. After the discharge temperature reaches 200°F [93°C], the Inverter will gradually increase the compressor RPM until the compressor returns to normal speed based on the capacity demand. Should the discharge temperature rise to 235°F [113°C] again, the Inverter to repeat the speed reduction cycle to maintain a temperature below 235°F [113°C].

## 8.4 High Discharge Pressure

The High Pressure Control (HPC) limits the compressor discharge pressure to a safe level to prevent damage to the compressor. When the HPC contacts open at 610 PSIG [4206 kPa], the compressor will proceed to shut down and restart per the sequence shown below. If the HPC contacts open three (3) times during the same call for operation, the EcoNet™ Control Center will display a High Refrigerant Pressure Lockout fault on the screen. A manual reset is required for the UODC to exit the compressor lock-out mode and clear the fault. This is accomplished by disconnecting the electrical power to **both** the indoor and outdoor units for 1 minute and then reconnecting power.

**NOTE: If the system experiences a high refrigerant pressure lock-out, the system should be evaluated to determine the cause for the high pressure condition and corrective action taken to eliminate the cause. Possible causes include excessive refrigerant charge, a failed indoor blower motor, dirty return air filter, or a dirty indoor coil (heating mode) or excessive refrigerant charge, a failed outdoor motor, or dirty outdoor coil (cooling mode).**

## 8.5 Low Suction Pressure/ Loss of Charge

The Universal Outdoor Control (UODC) continuously monitors the Suction Pressure Transducer input and will protect the compressor from damage by shutting it down when the suction pressure drops below 50 PSIG [345 kPa] in the cooling mode and below 15 PSIG [103 kPa] in the heating mode. A low pressure condition can result from inadequate indoor air-flow, low refrigerant charge or a restriction in the refrigerant circuit. The UODC will allow the compressor to restart if the suction pressure rises to 95 PSIG [655 kPa] in the cooling mode and 40 PSIG [276 kPa] in the heating mode. A low refrigerant pressure fault will be ignored for the first 90 seconds of compressor operation and during the entire defrost cycle to eliminate nuisance faults.

# 8.0 ACTIVE SYSTEM PROTECTION FEATURES

If there are 3 low pressure faults in the same call for cooling or during 120 minutes of continuous heating operation, the UODC will lock the compressor out and the EcoNet™ Control Center will display a Low Refrigerant Pressure Lockout fault on the screen. If the outdoor ambient is below -10°F [-23°C] in the heating mode when the lockout occurs, the control will automatically reset when the outdoor ambient rises to -10°F [-23°C]. If the outdoor ambient is above -10°F [-23°C], a manual reset is required for the VSODU to exit the compressor lock-out mode and clear the fault. This is accomplished by disconnecting the electrical power to **both** the indoor and outdoor units for 1 minute and then reconnecting power.

**NOTE:** If the system experiences a low refrigerant pressure lock-out, the system should be evaluated to determine the cause for the low pressure condition and corrective action taken to eliminate the cause. Possible causes include low refrigerant charge, failed indoor blower motor, dirty return air filter, or a dirty indoor coil in the cooling mode or low refrigerant charge, a failed outdoor motor, or a dirty outdoor coil in the heating mode.

## 8.6 Compressor Shut-Down Sequence for High or Low Refrigerant Pressure Fault

1. The compressor is commanded to operate at zero (0) RPM for a minimum of 5 minutes.
2. The outdoor fan motor will continue to operate during the 5 minute compressor off delay.
3. The UODC and EcoNet™ Control Center will display the applicable fault code.
4. If after 5 minutes cooling or heating demand persists and the pressure has reached reset conditions, normal system operation will resume and the fault codes will be cleared from the UODC and EcoNet™ Control Center displays.
5. If after 5 minutes cooling or heating demand persists and the pressure has not reached reset conditions, the outdoor fan motor will be shut down. Once the pressure reaches reset conditions after the 5 minute delay, normal system operation will resume.

## 8.7 Overcurrent and Current Imbalance

If the compressor current exceeds an acceptable level for the compressor or inverter, the inverter will reduce the compressor speed to allow the current to return to an acceptable level. If there is a current imbalance between the compressor 3-phase windings, the inverter will shut the compressor down for 5 minutes and will lock the compressor out if there are 3 faults within a single call for operation.

## 8.8 Compressor Operation Outside Envelope

If the inverter detects that the compressor motor torque exceeds an acceptable level for the compressor, the inverter will reduce the compressor speed to keep the torque at an acceptable level.

## 8.9 Over and Under Voltage

If the supply voltage or internal DC voltage is not within an acceptable operating range, the inverter will shut the compressor off until the voltage returns to an acceptable level.

## 8.10 Inverter Over Temperature

If the internal inverter temperature sensors detect excessive temperatures within the inverter, the inverter will reduce the speed of the compressor or shut the compressor down until the temperatures drop to an acceptable level. The compressor will be locked out if there are 3 faults within a single call for operation.

## 8.11 Controls and Communication Malfunction

If the controls senses a malfunction within the control system or communications or if system model data is not available, the controls will act to shut the system down to prevent the system from operating at a condition that could harm components.

# 8.0 ACTIVE SYSTEM PROTECTION FEATURES

## 8.12 Sensor Failure Default Operation

If the controls sense an externally connected sensor has failed, the system will enter a fail safe operating mode and will continue to condition the space until the sensor can be replaced. A fault code will be

displayed on the EcoNet™ Control Center and Universal Outdoor Control identifying which sensor has failed. See the table below for the default operation for a sensor failure.

FAILED COMPONENT	FUNCTION	DEFAULT OPERATION
Outdoor Sensor (OAT)	Low Ambient Cooling	No Low Ambient function
	Defrost	Defrost will be initiated based on coil temperature and time
	One minute fan off delay on COOL mode	No delay functions if failure is open or short. Continue function for a thermistor range error.
	PWM Shift above 104°F [40°C]	Shift will not occur
Coil Sensor	Defrost Initiate and Terminate	Defrost will occur at each time interval, but will terminate after 5 minutes
	Low Ambient Cooling	No function

## 8.13 Exiting Active Protection Lock-Out Mode

Exiting an Active Protection Lock-Out mode can be accomplished by disconnecting electrical power to both the indoor and outdoor units for 1 minute and then restoring power. Keep in mind there was a reason for the lock-out, so the fault

code on the Universal Outdoor Control (UODC) or EcoNet™ Control Center should be read to assist with diagnosing the root cause of the lock-out and corrective action should be taken to prevent the system from repeating the lock-out.

# 9.0 DIAGNOSTICS & TROUBLESHOOTING

Advanced operating status and diagnostic information is available through the EcoNet™ Control Center that greatly enhances the ability to quickly and accurately diagnose system faults. For further assistance for troubleshooting a system please see the Bluetooth Contractor's App or the Econect Help Pages at myrheem.com.

EcoNet Fault Code	Response Action
A001_0 Model Data Configuration Error	Lockout while active, short cycle to restart.
A002_0 Compressor Model Data Error	Lockout while active, short cycle to restart.
A003_0 Fan Model Data Error	Lockout while active, short cycle to restart.
A093_0 Model Data Restore Failure	Lockout while active, short cycle to restart.
A100_0 Communications Lost with Indoor Unit	Lockout while active, short cycle to restart.
A906_0 Inverter Fault - AC Input Overvoltage	Lockout while active, short cycle to restart.
A907_0 Inverter Fault - AC Input Undervoltage	Lockout while active, short cycle to restart.
A910_0 Inverter Fault - Lost Rotor Position	3-strikes to permanent lockout
A912_0 Inverter Fault - Self-Check Fault	Lockout while active, short cycle to restart.
A915_0 Inverter Fault - Comm Fault	Lockout while active, short cycle to restart.
A920_0 Inverter Fault - PFC Desaturation	3-strikes to permanent lockout
A924_0 Inverter Fault - Board Temp	3-strikes to permanent lockout
A925_0 Inverter Fault - Comp. Model Unknown	Lockout while active, short cycle to restart.
A926_0 Inverter Fault - HP Sensor Not Configured	Lockout while active, short cycle to restart.
A927_0 Inverter Fault - Drive Configuration	Lockout while active, short cycle to restart.
A928_0 Locked Out - See History Faults	Permanent lockout
A929_0 240V Missing or Inverter Comm Failure	Lockout while active, short cycle to restart.
A950_0 Configuration Data Restore Failure	Lockout while active, short cycle to restart.
A953_0 Coil Temp Thermistor Failure	Algorithms default
A954_0 Suction Temp Thermistor Failure	Algorithms default
A956_0 Suction Pressure Sensor Failure	Algorithms default
A957_0 Low Refrigerant Pressure	4-hour lockout
A958_0 High Refrigerant Pressure	4-hour lockout
A960_0 Compressor Locked Rotor - Lockout	Permanent lockout
A970_0 Inverter/Compressor Mismatch	Permanent lockout
A975_0 Contactor Stuck On	Lockout while active, short cycle to restart.
A979_0 Compressor Over/Under Speed	3-strikes to permanent lockout
A980_0 Fan Self Check Fault	Lockout while active, short cycle to restart.
A987_0 Compressor Loss of Phase	3-strikes to permanent lockout
A988_0 Compressor Control Lost	3-strikes to permanent lockout
A989_0 Charge Relay Open	3-strikes to permanent lockout
A990_0 Compressor U-Phase Over Current	3-strikes to permanent lockout
A991_0 Compressor V-Phase Over Current	3-strikes to permanent lockout
A992_0 Compressor W-Phase Over Current	3-strikes to permanent lockout
A993_0 Compressor Module Over Current	3-strikes to permanent lockout
A994_0 Compressor Parameter Fault	Lockout while active, short cycle to restart.
A998_0 Fan Motor Parameter Fault	Lockout while active, short cycle to restart.
T901_0 Inverter Fault - Comp. Overcurrent	3-strikes to permanent lockout
T902_0 Inverter - Envelope Protection	Follow req. M1HPC-SR-79

# 9.0 DIAGNOSTICS & TROUBLESHOOTING

Advanced operating status and diagnostic information is available through the EcoNet™ Control Center that greatly enhances the ability to quickly and accurately diagnose system faults. For further assistance for troubleshooting a system please see the Bluetooth Contractor's App or the Econect Help Pages at myrheem.com.

T903_0 Inverter Fault - PFC Overcurrent	3-strikes to permanent lockout
T904_0 Inverter Fault - DC Bus Overvoltage	3-strikes to 30 minute lockout
T905_0 Inverter Fault - DC Bus Undervoltage	Lockout while active, short cycle to restart.
T908_0 Inverter Fault - PIM Over-temp	3-strikes to permanent lockout
T909_0 Inverter Fault - PFC Over-temp	3-strikes to permanent lockout
T911_0 Inverter Fault - Current Imbalance	3-strikes to permanent lockout
T914_0 Inverter Fault - DC Voltage Low	3-strikes to permanent lockout
T916_0 Inverter Fault - Discharge Line Temp	3-strikes to permanent lockout
T917_0 Inverter Fault - PIM Temp	3-strikes to permanent lockout
T918_0 Inverter Fault - PFC Temp	3-strikes to permanent lockout
T922_0 Inverter Fault - PIM Temp Foldback	3-strikes to permanent lockout
T923_0 Inverter Fault - High Refrig Pressure	3-strikes to 4-hour lockout
T931_0 Fan Fault Phase Over Current	3-strikes to permanent lockout
T932_0 Fan Fault Phase Current Imbalance	3-strikes to permanent lockout
T933_0 Fan Fault Motor Over/Under Speed	3-strikes to permanent lockout
T934_0 Fan Fault U-Phase Over Current	3-strikes to permanent lockout
T935_0 Fan Fault V-Phase Over Current	3-strikes to permanent lockout
T936_0 Fan Fault W-Phase Over Current	3-strikes to permanent lockout
T937_0 Fan Fault Module Over Current	3-strikes to permanent lockout
T938_0 Fan Fault Loss of Phase	3-strikes to permanent lockout
T939_0 Fan Fault Loss of Control	3-strikes to permanent lockout
T940_0 Fan Fault Module Over Temperature	3-strikes to permanent lockout
T941_0 Fan Fault Start Up Fault	3-strikes to permanent lockout
T942_0 Fan Fault Module Temp High	3-strikes to permanent lockout
T952_0 Outside Temp Thermistor Failure	Algorithms default
T955_0 Compressor Temp Thermistor Failure	Algorithms default
T957_0 Low Refrigerant Pressure	3-strikes to 4-hour lockout
T960_0 Compressor Locked Rotor	6-strikes to permanent lockout
T961_0 Discharge Temp Thermistor Failure	Algorithms default
T971_0 Compressor Lube Protection	Follow req. M1HPC-SR-80
T972_0 Compressor Discharge Temp High	Follow req. M1HPC-SR-81
T974_0 Line Current Trip	3-strikes to permanent lockout
T981_0 Fan Overcurrent Trip	3-strikes to permanent lockout
T982_0 Fan Overvoltage Trip	3-strikes to permanent lockout
T983_0 Fan Undervoltage Fault	3-strikes to permanent lockout
T984_0 Fan Locked Rotor Fault	3-strikes to permanent lockout
T986_0 High Refrigerant Pressure Envelope	3-strikes to permanent lockout
T995_0 IPM Overcurrent Trip	3-strikes to permanent lockout
T996_0 Low Side Overcurrent Trip	3-strikes to permanent lockout
T997_0 High Side Overcurrent Trip	3-strikes to permanent lockout

# 9.0 DIAGNOSTICS & TROUBLESHOOTING



## 9.1 Checking Transducers & Temperature Sensors

### TRANSDUCERS:

Checking transducers for accuracy can be tricky. A technician will be required to do some voltage reading and math to validate the transducer is functioning properly. Additionally, comparing it to a reliable source can also be a challenge. Unless the gauges have been calibrated recently, the question remains, which one is right?

Knowing where to take the measurement, and getting solid reading is crucial. Measurements are done in the 0-5 volt DC range. One confusing point may be that we will take our measurements OUT and IN to the control, which are reversed when we talk formulas because we want the IN and OUT of the transducer. For instance, 5VDC out of the control board, translates to 5VDC into the transducer. And the lower variable voltage output from the transducer will be the input to the control board.

The transducer is not removed or disconnected to make these checks. The technician's meter leads need to be the smaller needle type, or actual needles can be used to gain access to the points of measurements.

Formulas for calculating gauge pressure are shown below.

### SUCTION LINE TRANSDUCER:

$$\text{PSIG} = 375 * (\text{VDC out} / \text{VDC in}) - 8.1$$

### LIQUID LINE TRANSDUCER:

$$\text{PSIG} = 812.5 * (\text{VDC out} / \text{VDC in}) - 51.85$$

**IMPORTANT:** Do the division inside the parenthesis first, multiplication second, and subtraction last.

### SUCTION LINE TRANSDUCER:

$$\text{VDC out} = 2.4$$

$$\text{VDC in} = 5.1$$

So...

$$\text{PSIG} = 375 * (2.4 / 5.1) - 8.1$$

$$\text{PSIG} = 375 * (0.47) - 8.1$$

$$\text{PSIG} = 176.25 - 8.1$$

$$\text{PSIG} = \mathbf{138.75}$$

### LIQUID LINE TRANSDUCER:

$$\text{VDC out} = 3.4$$

$$\text{VDC in} = 5.1$$

So...

$$\text{PSIG} = 812.50 * (3.4 / 5.1) - 51.85$$

$$\text{PSIG} = 812.50 * (0.667) - 51.85$$

$$\text{PSIG} = 541.67 - 51.85$$

$$\text{PSIG} = \mathbf{460.40}$$

The pressures are best measured when the system is off since they will be the most stable.

The indoor transducer may be removed so the pressure can be checked with gauges at the actual port the transducer is connected to. Pressures for outdoor transducers can be checked at the outdoor unit service ports with gauges since they are close enough in proximity to the transducers.

With the system powered, use the smaller meter tips to measure the voltage at the back of the transducer harness where it plugs into the control board. Voltage In will be measured from the Red and Black wires. (Red is +, Black is -). This should be very close to 5VDC, but may vary by a few 1/10ths. Voltage Out will be measured from Green to Black. (Green is the variable +, Black remains -).



# 9.0 DIAGNOSTICS & TROUBLESHOOTING



## 9.1 Checking Transducers & Temperature Sensors (cont.)

### TEMPERATURE SENSORS:

All the temperature sensors/thermistors used in the equipment use the same scale of 10,000 Ohms at 77°F (25°C). This means, a sensor exposed to 77°F will show a resistance of 10,000 Ohms +/- 1%. As the temperature decreases, the resistance increases. Alternatively, as the temperature increases, the resistance decreases.

Measurements will be made with the sensor disconnected from the control board. Again, comparing the results must be done against a calibrated tester.

A glass of water, mixed completely with ice chips and given several minutes to settle should measure 32 to 32.4°F. [0 - 0.2 °C]

Apply resistance measurements to the chart found below and compare to the control.

32° will have a resistance +/- 1% of 32,650 Ohms.

*In the event Celsius is being used, the Fahrenheit temperature will need to be converted.*

$$^{\circ}\text{C} = (^{\circ}\text{F} - 32) * 5 / 9$$

*Example using 82°F*

$$^{\circ}\text{C} = (82 - 32) * 5 / 9$$

$$^{\circ}\text{C} = (50) * 5 / 9$$

$$^{\circ}\text{C} = 250 / 9$$

$$^{\circ}\text{C} = 27.8$$

Temp F°	Ohms	Temp F°	Ohms	Temp F°	Ohms	Temp F°	Ohms
0	85,378	33	31,738	66	13,138	99	5,961
1	82,710	34	30,855	67	12,811	100	5,827
2	80,135	35	30,000	68	12,493	101	5,697
3	77,649	36	29,171	69	12,184	102	5,570
4	75,249	37	28,376	70	11,883	103	5,446
5	72,931	38	27,589	71	11,591	104	5,326
6	70,693	39	26,834	72	11,307	105	5,208
7	68,531	40	26,103	73	11,031	106	5,094
8	66,442	41	25,394	74	10,762	107	4,982
9	64,475	42	24,706	75	10,501	108	4,873
10	62,475	43	24,039	76	10,247	109	4,767
11	60,592	44	23,393	77	10,000	110	4,663
12	58,771	45	22,766	78	9,760	111	4,562
13	57,012	46	22,158	79	9,526	112	4,464
14	55,311	47	21,568	80	9,298	113	4,368
15	53,667	48	20,996	81	9,077	114	4,274
16	52,077	49	20,441	82	8,862	115	4,183
17	50,540	50	19,902	83	8,651	116	4,094
18	49,054	51	19,379	84	8,448	117	4,007
19	47,616	52	18,872	85	8,250	118	3,922
20	46,225	53	18,379	86	8,056	119	3,839
21	44,880	54	17,902	87	7,868	120	3,758
22	43,578	55	17,438	88	7,685	121	3,679
23	42,318	56	16,987	89	7,507	122	3,602
24	41,099	57	16,550	90	7,333	123	3,527
25	39,920	58	16,125	91	7,164	124	3,453
26	38,778	59	15,713	92	7,000	125	3,382
27	37,672	60	15,312	93	6,839	126	3,312
28	36,602	61	14,923	94	6,683	127	3,243
29	35,566	62	14,545	95	6,531	128	3,177
30	34,563	63	14,178	96	6,383	129	3,112
31	33,591	64	13,822	97	6,238	130	3,048
32	32,650	65	13,475	98	6,098		

# 9.0 DIAGNOSTICS & TROUBLESHOOTING



## 9.2 General Troubleshooting Guide

**⚠️ WARNING:** Disconnect all power to unit before servicing. Contactor may break only one side. Failure to shut off power can cause electrical shock resulting in personal injury or death.

SYMPTOM	POSSIBLE CAUSE	REMEDY
Unit will not run	<ul style="list-style-type: none"> <li>Power off or loose electrical connection</li> <li>Thermostat set too high or low.</li> <li>Unit in active compressor protection lockout mode</li> <li>Blown fuses/tripped breaker</li> <li>Transformer defective</li> <li>High-pressure control lock-out</li> <li>Low-pressure control lock-out</li> <li>Miswiring of communications (communication light on continuously)</li> <li>Defective control board</li> </ul>	<ul style="list-style-type: none"> <li>Check for correct voltage at line voltage connections in condensing unit.</li> <li>Reset – Power cycle high and low voltage to outdoor unit.</li> <li>Check control board diagnostic codes.</li> <li>Replace fuses/reset breaker.</li> <li>Check wiring. Replace transformer.</li> <li>Reset by cycling power to unit. Also see high head pressure and low suction pressure remedies.</li> <li>Check for refrigerant leaks.</li> <li>Check communication wiring.</li> </ul>
Outdoor fan runs, compressor doesn't	<ul style="list-style-type: none"> <li>Loose connection</li> <li>Communication cable disconnected or failed</li> <li>Compressor stuck, grounded or open motor winding, open internal overload.</li> <li>Low-voltage condition</li> </ul>	<ul style="list-style-type: none"> <li>Check for correct voltage at filter and inverter. Check and tighten all connections.</li> <li>Check control board diagnostic codes.</li> <li>Replace</li> </ul>
Insufficient cooling	<ul style="list-style-type: none"> <li>Improperly sized unit</li> <li>Improper indoor airflow</li> <li>Incorrect refrigerant charge</li> <li>Air, noncondensibles, or moisture in system</li> <li>Restricted Refrigerant Circuit</li> </ul>	<ul style="list-style-type: none"> <li>Recalculate load.</li> <li>Check airflow. Should be approximately 400 CFM [189 l/s] per ton.</li> <li>Charge per procedure attached to unit service panel.</li> <li>Recover refrigerant. Evacuate and recharge. Replace filter drier.</li> <li>Locate restriction and clear</li> </ul>
Compressor short cycles	<ul style="list-style-type: none"> <li>Incorrect voltage</li> <li>Improperly sized unit</li> <li>Refrigerant undercharge or overcharge (LPC or HPC Cycling)</li> </ul>	<ul style="list-style-type: none"> <li>At inverter input terminals, voltage must be between 187-252 VAC when unit is operating.</li> <li>Adjust charge per charging chart.</li> </ul>
Registers sweat	<ul style="list-style-type: none"> <li>Low indoor airflow</li> </ul>	<ul style="list-style-type: none"> <li>Increase speed of blower or reduce restriction. Replace air filter.</li> </ul>
High head, low vapor pressures	<ul style="list-style-type: none"> <li>Restriction in liquid line, expansion device, or filter drier</li> <li>Stuck TXV</li> </ul>	<ul style="list-style-type: none"> <li>Remove or replace defective component.</li> <li>Verify TXV operation.</li> </ul>
High head, high or normal vapor pressure – Cooling mode	<ul style="list-style-type: none"> <li>Dirty outdoor coil</li> <li>Refrigerant overcharge</li> <li>Outdoor fan not running</li> <li>Air or noncondensibles in system</li> </ul>	<ul style="list-style-type: none"> <li>Clean coil.</li> <li>Correct system charge.</li> <li>Repair or replace.</li> <li>Recover refrigerant. Evacuate and recharge.</li> </ul>
Low head, high vapor pressures	<ul style="list-style-type: none"> <li>Reversing Valve leaking by</li> <li>Bad compressor</li> </ul>	<ul style="list-style-type: none"> <li>Verify thermistor and pressure transducer connection and operation</li> <li>Replace reversing valve</li> <li>Replace compressor.</li> </ul>
Low vapor, cool compressor, iced indoor coil	<ul style="list-style-type: none"> <li>Low indoor airflow</li> <li>Operating below 55°F outdoors</li> <li>Moisture in system</li> <li>Low ambient cooling not operating (coil or ambient thermistor failure)</li> </ul>	<ul style="list-style-type: none"> <li>Increase speed of blower or reduce restriction. Replace air filter.</li> <li>Recover refrigerant. Evacuate and recharge. Replace filter drier.</li> </ul>
High vapor pressure	<ul style="list-style-type: none"> <li>Excessive load</li> <li>Defective compressor</li> </ul>	<ul style="list-style-type: none"> <li>Recheck load calculation.</li> <li>Replace compressor.</li> </ul>
Fluctuating head and vapor pressures	<ul style="list-style-type: none"> <li>TXV hunting</li> <li>Air or noncondensibles in system</li> </ul>	<ul style="list-style-type: none"> <li>Check thermistor to vapor line connection. Check air distribution on coil.</li> <li>Check suction thermistor and pressure transducer operation</li> <li>Recover refrigerant. Evacuate and recharge.</li> <li>Remove &amp; confirm TXV movement. Clean TXV inside with nitrogen to remove any debris then reinstall</li> </ul>
Gurgle or pulsing noise at expansion device or liquid line	<ul style="list-style-type: none"> <li>Air or noncondensibles in system</li> <li>Undercharge long line application</li> </ul>	<ul style="list-style-type: none"> <li>Recover refrigerant. Evacuate and recharge.</li> <li>Adjust charge per charging chart.</li> </ul>

# 9.0 DIAGNOSTICS & TROUBLESHOOTING



## 9.3 Service Analyzer Charts

Diagnostics

COMPRESSOR OVERHEATING – HIGH DISCHARGE TEMP			
SYMPTOM	POSSIBLE CAUSE	REMEDY	
High superheat (greater than 15°F [-8.3°C] at coil)	Low charge	Check system charge.	
	Verify suction thermistor operation (10k thermistor)	Replace thermistor.	
	Verify pressure transducer operation input and output voltage	Replace thermistor and/or harness and/or control board.	
	Faulty metering device, inadequate suction thermistor or pressure transducer operation.	Restricted cap tube, TXV	
		Foreign matter stopping flow	
	High internal load	Hot air (attic) entering return	
		Heat source on; miswired or faulty control	
	Restriction in liquid line	Drier plugged.	
		Line kinked.	
	Low head pressure	Low charge	
Operating in low ambient temperatures			
Vapor or liquid line subjected to high heat source	Hot attic		
	Hot water line		
Low line voltage	Loose wire connections	Check wiring.	
	Power company problem, transformer	Report problem.	
	Undersized wire feeding unit	Correct and complete diagnosis.	
High head pressure	Overcharge	Check system charge.	
	Dirty heat pump coil	Clean coil.	
	Faulty or wrong size heat pump fan motor	Replace fan motor.	
	Faulty fan blade or wrong rotation	Replace fan blade.	
		Replace with correct rotation motor.	
	Recirculation of air	Correct installation.	
	Additional heat source	Check for dryer vent near unit.	
		Check for recirculation from other equipment.	
Noncondensibles	Recover refrigerant. Evacuate and recharge system.		
Equipment not matched	Correct mismatch.		
Short cycling of compressor	Cycling or faulty pressure control	Check pressure and address cause of high or low pressure. Replace pressure control if faulty.	
	Loose wiring	Check unit wiring.	
	Thermostat	Located in supply air stream	
		Differential setting too close	
		Customer misuse	
	TXV restricted or not functioning properly	Internal foreign matter	
		Pressure transducer failure	
		Suction thermistor failure	
	Distributor tube restricted	Restricted with foreign matter	
		Kinked	
Inside diameter reduced from previous compressor failure			

# 9.0 DIAGNOSTICS & TROUBLESHOOTING



## 9.3 Service Analyzer Charts (cont.)

COMPRESSOR OVERHEATING – HIGH DISCHARGE TEMP (cont.)		
SYMPTOM	POSSIBLE CAUSE	REMEDY
Short cycling of compressor (cont.)	Low charge	Check system charge.
	Low evaporator airflow	Dirty coil
		Dirty filter
		Duct too small or restricted
Faulty internal overload	Replace compressor.	

ELECTRICAL		
SYMPTOM	POSSIBLE CAUSE	REMEDY
Voltage present on load side of inverter and compressor won't run	Communication failure from UODC to inverter.	Check communication harness connectors and wire continuity.
	Compressor windings	Check for correct ohms.
187 – 252VAC present at input to inverter	Thermostat	Check for control voltage to contactor coil.
	Compressor control circuit	High-pressure switch
		Low-pressure cut-out
		Ambient thermostat
		Stater heat is active
		Compressor timed off/on control or interlock
No voltage at input to inverter	Blown fuses or tripped circuit breaker	Check for short in wiring or unit.
	Improper wiring	Recheck wiring diagram.
Improper voltage	High voltage	Wrong unit
		Power supply problem
	Low voltage	Wrong unit
		Power supply problem
		Wiring undersized
		Loose connections

FLOODED STARTS		
SYMPTOM	POSSIBLE CAUSE	REMEDY
Liquid in the compressor shell	Faulty stator heat circuit (single leg output to compressor)	Check inverter for single leg output power and correct wiring.
Too much liquid in system	Incorrect piping	Check piping guidelines.
	Overcharge	Check and adjust charge.

CONTAMINATION		
SYMPTOM	POSSIBLE CAUSE	REMEDY
Moisture	Poor evacuation on installation or during service	In each case, the cure is the same. Recover refrigerant, flush system. Add filter driver, evacuate, and recharge.
High head pressure	Noncondensibles air	
Unusual head and suction pressure readings	Wrong refrigerant or mixed refrigerants	
Foreign matter – copper filings	Copper tubing cuttings	
Copper oxide	Dirty copper piping or nitrogen not used when brazing	
Welding scale	Nitrogen not used during brazing	
Soldering flux	Adding flux before seating copper partway	
Excess soft solder	Wrong solder material	

# 9.0 DIAGNOSTICS & TROUBLESHOOTING



## 9.3 Service Analyzer Charts (cont.)

Diagnostics

<b>LOSS OF LUBRICATION</b>		
<b>SYMPTOM</b>	<b>POSSIBLE CAUSE</b>	<b>REMEDY</b>
Compressor failures	Vapor line tubing too large	Reduce tubing size to improve oil return.
Low suction pressure	Low charge	Check system charge.
	Refrigerant leaks	Repair and recharge.
Cold, noisy compressor – Slugging	Dilution of oil with refrigerant	Observe piping guidelines.
Noisy compressor	Migration	Check stater heat and compressor thermistor.
Cold, sweating compressor	Flooding	Check system charge.
Low load	Reduced airflow	Dirty filter
		Dirty coil
		Wrong duct size
		Restricted duct
	Thermostat setting	Advise customer.
Short cycling of compressor	Cycling or faulty high or low pressure control	Check pressure and address cause of any abnormal pressure. Replace control if faulty.
	Loose wiring	Check all control wires.
	Thermostat	In supply air stream, out of calibration
		Customer misuse
<b>LIQUID REFRIGERANT SLUGGING</b>		
<b>SYMPTOM</b>	<b>POSSIBLE CAUSE</b>	<b>REMEDY</b>
On start-up	Incorrect piping	Review pipe size guidelines.
TXV hunting when running	Faulty TXV components	Check TXV, suction pressure transducer, and suction thermistor for operation.
<b>REFRIGERANT FLOOD BACK</b>		
<b>SYMPTOM</b>	<b>POSSIBLE CAUSE</b>	<b>REMEDY</b>
Poor system control using an TXV	Bad pressure reading	Check transducer wiring.
	Suction thermistor in wrong location	Relocate thermistor.
	Bad suction thermistor	Replace thermistor.



# 9.0 DIAGNOSTICS & TROUBLESHOOTING



## 9.3 Service Analyzer Charts (cont.)

THERMOSTATIC EXPANSION VALVES		
SYMPTOM	POSSIBLE CAUSE	REMEDY
High Superheat, Low Suction Pressure (superheat over 15°F [8.3°C])	Moisture freezing and blocking valve	Recover charge, replace filter-drier, evacuate system, recharge.
	Dirt or foreign material blocking valve	Recover charge, replace filter-drier, evacuate system, recharge
	Low refrigerant charge	Correct the charge.
	Vapor bubbles in liquid line	Remove restriction in liquid line. Correct the refrigerant charge.
		Remove noncondensable gases.
		Size liquid line correctly.
	Undersized TXV	Replace with correct valve.
	Incorrectly sensing vapor line temperature	Verify suction thermistor resistance is correct and properly attached and insulated to the vapor line.
	Suction thermistor incorrectly calibrated.	Replace suction thermistor assembly.
	Vapor pressure measured incorrectly.	After verifying lack of connectivity, replace the pressure transducer or harness.
		If harness has a short, replace harness
		If gauge pressure measurement and the converted voltage readings at the control are different replace pressure transducer
		If gauge pressure measurement and the converted voltage readings at the control are the same, replace the control.
	TXV is stuck	Remove TXV from the system and purge with nitrogen, replace filter drier, and recharge.
If none of the above rectifies the issue, replace TXV and filter drier and recharge.		
UODC DC circuit failed	Verify 5Vdc to pressure transducer is present. If not, replace UODC.	
High superheat adjustment	Change the superheat offset dip switches to increase superheat.	
Valve feeds too much refrigerant, with low superheat, with low superheat and higher than normal suction pressure.	Moisture causing valve to stick open.	Recover refrigerant, replace filter-drier, evacuate system, and recharge.
	Dirt or foreign material causing valve to stick open	Recover refrigerant, replace filter-drier, remove TXV and purge with nitrogen, evacuate system, and recharge.
		If TXV is completely clogged use the UODC to open the TXV, and purge with nitrogen, replace filter drier, and recharge.
	Oversized TXV	Install correct TXV.
	Incorrect suction thermistor location	Install suction thermistor with the provided stainless steel strap and an additional zip tie between the 10:00 and 2:00 position on suction line, with insulation.
	Low superheat adjustment	Change the superheat offset dip switches to increase superheat.
	Incorrectly sensing vapor line temperature	Verify suction thermistor resistance is correct and properly attached and insulated to the vapor line.
	Suction thermistor incorrectly calibrated.	Replace suction thermistor assembly.
Vapor pressure measured incorrectly.	After verifying lack of connectivity, replace the pressure transducer or harness.	
	If harness has a short, replace harness.	
	If gauge pressure measurement and the converted voltage readings at the control are different replace pressure transducer.	
	If gauge pressure measurement and the converted voltage readings at the control are the same, replace the control.	

# 9.0 DIAGNOSTICS & TROUBLESHOOTING



## 9.3 Service Analyzer Charts (cont.)

THERMOSTATIC EXPANSION VALVES (cont.)		
SYMPTOM	POSSIBLE CAUSE	REMEDY
Low load	Reduced airflow	Dirty filter
		Dirty coil
		Wrong duct size
		Restricted duct
	Thermostat setting	Advise customer.
Compressor flood back upon start-up	Refrigerant drainage from flooded evaporator	Install trap riser to the top of the evaporator coil.
	Inoperable stator heat	
Superheat is low to normal with low suction pressure	Unequal evaporator circuit loading	Recover refrigerant, replace filter-drier, evacuate system, and recharge.
		Check for blocked distributor tubes.
	Low load or airflow entering evaporator coil	Ensure blower is moving proper air CFM.
		Remove/Correct any airflow restriction.
Superheat and suction pressure fluctuate (valve is hunting)	Expansion valve is oversized.	Install correct TXV
	Section thermistor is affected by liquid refrigerant or refrigerant oil flowing through suction line	Relocate sensing bulb in another position around the circumference of the suction line.
	Unequal refrigerant flow through evaporator circuit	Ensure sensing bulb is located properly.
		Check for blocked distributor tubes.
Moisture freezing and partially blocking TXV	Recover refrigerant, change filter-drier, evacuate system, and recharge.	
Valve does not regulate at all	Pressure transducer not connected or plugged	Connect pressure transducer in proper location, or remove any blockage.
	Suction line thermistor not connected, or installed on heat effected zone.	Install suction line thermistor in correct horizontal clean section of copper pipe.
	Suction line thermistor failed (continuity to control, wire damaged, resistance values incorrect)	Replace suction line thermistor.

# 9.0 DIAGNOSTICS & TROUBLESHOOTING



## 9.4 Troubleshooting Tips

Cooling Mode Trouble Shooting Tips

SYSTEM PROBLEM	INDICATORS			
	DISCHARGE PRESSURE	SUCTION PRESSURE	SUPERHEAT Normal: 5°–15°F [2.8° – 8.3°C]	SUBCOOLING Normal: See Charging Chart
Overcharge	High	High	Low	High
Undercharge	Low	Low	High	Low
Liquid Restriction (Filter Drier)	Low	Low	High	High
Low Indoor Airflow	Low	Low	Low	Low
Dirty Outdoor Coil	High	High	Low	Low
Low Outdoor Ambient Temperature	Low	Low	High	High
Inefficient Compressor	Low	High	High	High
Bad Indoor Suction Pressure Transducer or Faulty Measurement	Low	Low	High	High
Poorly Insulated Indoor Vapour Line Thermistor or Bad Thermistor	High	High	Low	Low

Heating Mode Trouble Shooting Tips

SYSTEM PROBLEM	INDICATORS			
	DISCHARGE PRESSURE	SUCTION PRESSURE	SUPERHEAT Normal: 5°–15°F [2.8° – 8.3°C]	SUBCOOLING Normal: See Charging Chart
Overcharge	High	High	OK	High
Undercharge	Low	Low	OK or High	Low
Liquid Restriction (Filter Drier)	Low	Low	High	High
Low Outdoor Airflow	Low	Low	Low	Low
Dirty Indoor Coil	High	High	Low	Low
Low Indoor Ambient Temperature	Low	Low	OK	High
Inefficient Compressor	Low	High	High	High
Bad Outdoor Suction Pressure Transducer or Faulty Measurement	Low	Low	High	High
Poorly Insulated Outdoor Vapour Line Thermistor or Bad Thermistor	High	High	Low	Low

# 10.0 OUTDOOR UNIT MAINTENANCE



## 10.1 Outdoor Coil Cleaning

The outdoor fan draws air across the coil during operation which results in contaminants collecting on and between the aluminum fins. These contaminants restrict the air-flow through the coil resulting in reduced capacity and efficiency and increases the temperature of the components that can reduce their life. Therefore, it is recommended that the outdoor coil be cleaned at least annually by a qualified service technician using a non-corrosive coil cleaner and low pressure water hose sprayer. Care must be taken not to damage or flatten out the fins by spraying the fins from an angle. Washing from the top of the coil down

from the inside out is the most effective method of cleaning the coil. The exterior louver panels and unit top are easily removable to facilitate the coil cleaning task.

**WARNING: Disconnect electrical power to the unit before removing the top panel or any electrical panel as the fan motor could start at any time and live electrical connections will be exposed.**



## 10.2 Cabinet Cleaning and Care

Annual cleaning of the exterior cabinet is recommended using a mild detergent, water, and cloth/sponge to remove dust, mold, and potentially corrosive contaminants that have collected on the cabinet. It is also recommended to apply a good quality automotive wax to the painted metal cabinet parts annually to protect the finish and to restore the gloss of the paint. Do not apply wax to the plastic parts.



## 10.3 Motor Lubrication

The ball bearings in the outdoor motor are pre-lubricated by the motor manufacturer and do not have oiling ports. The motor will run for an indefinite period of time without additional lubrication.



## 10.4 Replacement Parts

Any replacement part used to replace parts originally supplied on equipment must be the same as or an approved alternate to the original part supplied. The manufacturer will not be responsible for replacement parts not designed to physically fit or operate within the design parameters the original parts were selected for.

# 11.1 Wiring Diagram - Heat pump

# 11.0 WIRING DIAGRAM

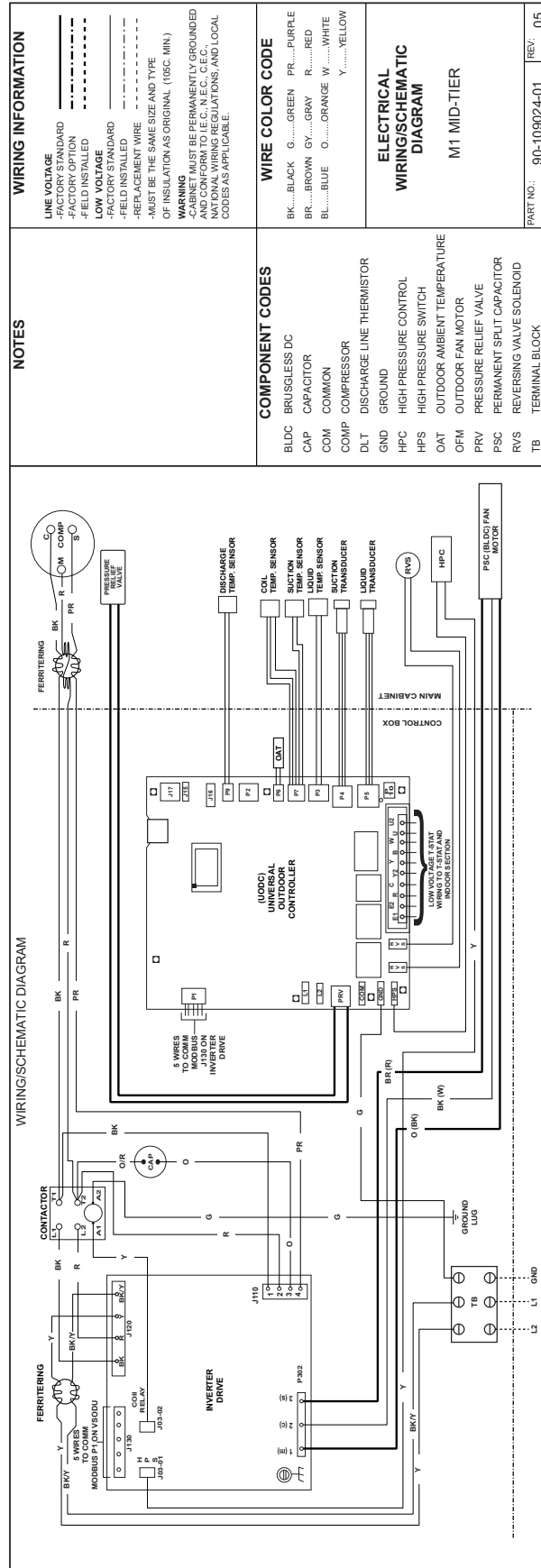



# 11.0 WIRING DIAGRAM

## 11.2 Wiring Diagram - Air Conditioner

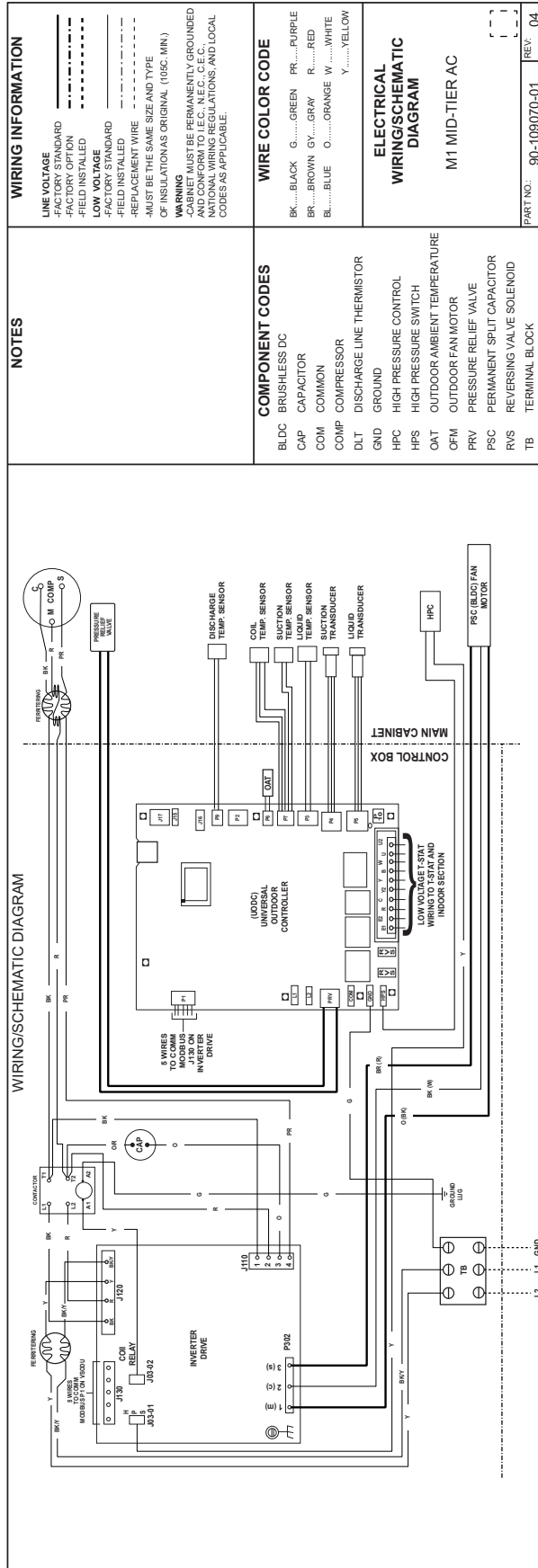

# 12.0 APPENDIX



## 12.1 Agency Performance Audit Test Instructions

Performance audit testing a (-)A15AZ/(-)P16AZ/(-)A16AZ variable speed outdoor unit's rated combination requires an EcoNet™ Control Center (according to the AHRI rating database) as an accessory to obtain the rated performance. Utilize the following instructions to properly operate the system during audit tests.

1. Install the rated system consistent with this manual and ASHRAE 37.
2. Leak check and charge the rated system per the instructions found in this manual.
3. Wire the outdoor unit, indoor air mover/furnace, indoor coil TXV control (when necessary), and EcoNet™ Control Center according to the following wiring diagrams.

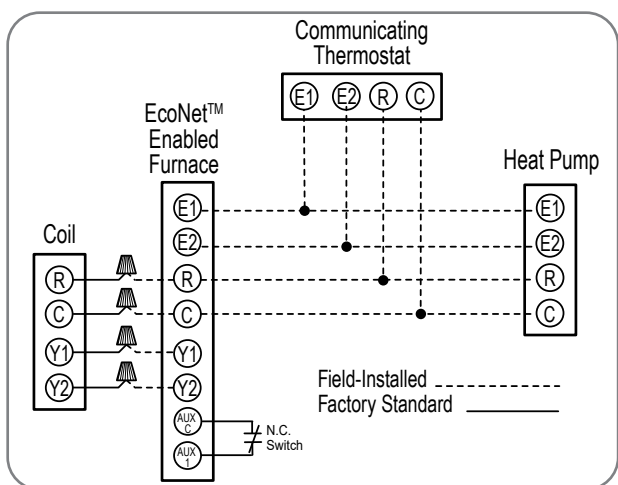
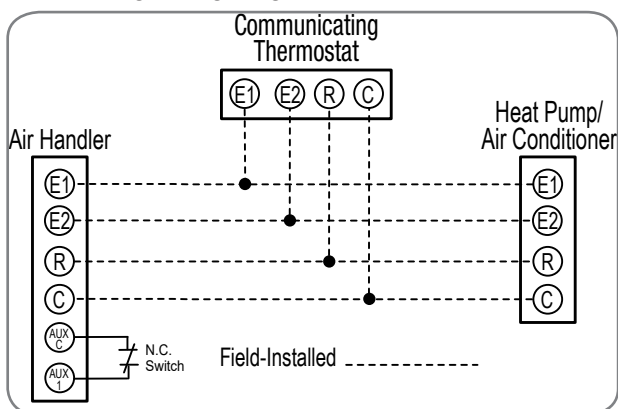

4. Supply high and low voltage to the system.
5. Once each control is powered turn off the Dehumidification feature:
  - a. Pressing the “Settings” button on the home screen followed by pressing the “humidity” button.
  - b. Once in the “humidity” screen, select “Yes” next to the “Enable Dehumidification ?” label.
  - c. To turn dehumidification off press the orange

up or blue down arrows once.

- d. The “Yes” should turn to a value of “No.”
6. Once the dehumidification feature is turned off, the Aux 1 configuration needs to be set to normally closed (N.C.) as to permit a closed switch attached to the Aux 1 contacts to keep the system operating. Thereby an open switch would indicate to the system to shut down:
  - a. Press the back arrow in the bottom left of the dehumidification screen to return to the “settings” screen.
  - b. Press the “installer” button in the bottom right corner of the “settings” screen.
  - c. Press the “air handler” or “furnace” button.
  - d. Once in the “air handler settings” or “furnace settings” screen select “N.C.” next to the “Aux Input #1 Config” label.
  - e. Change the “Aux #1 Config” type to “N.C.” by pressing the orange up or blue down arrows at the bottom of the screen twice.
  - f. Select “Off” next to the “Aux Input #1 Config” label.
  - g. Change the “Aux #1 Config” value from “Off” to “Shutdown” by pressing the orange up button at the bottom of the screen two times. After each press of the orange up button the value next to the “Aux #1 Config” label should change.
7. Entering the Test Mode
  - a. Press the back arrow in the bottom left of the screen 3 times to return to the home screen showing the inside temperature.
  - b. Press the “Service” button on the home screen.
  - c. Press the “ODU check-out” button in the bottom right corner of the “service” screen to enter the “installer checkout” screen.
  - d. Select the desired mode of operation by pressing “Off” next to the “Var Speed ODU Test” label and then the orange up arrow or blue down arrow at the bottom of the “installer checkout” screen.

**NOTE:** Any faults must be resolved before the system will start. See the troubleshooting guide in this manual for assistance.

**NOTE:** If the unit does not start when the “start” button is pushed verify the switch attached to the Aux 1 input on the air handler or furnace control board is closed and no alarms are active.

**NOTE:** In order to change from heating mode to cooling mode or vice versa the system must first be turned off by pressing the blue down

# 12.0 APPENDIX



## 12.1 Agency Performance Audit Test Instructions (cont.)

button until “stop test” appears at the bottom of the “installer checkout” screen. Then press the “Stop” button.

### 8. Cycle Testing

- a. The Aux #1 configuration performed above permits a N.C. set of contacts to be connected to these terminals on the air handler or the furnace controls.
- b. When performing the optional AHRI cycle tests, the Aux #1 terminals should be used to turn the unit on and off.
- c. When the system is desired to be operating the air handler or furnace control should sense continuity between the Aux #1 and Aux C terminals. This continuity will tell the system to turn on and the Test Mode selection outlined in step 7 above identifies the mode and stage of operation.
- d. When the unit is desired to be off/not operating the air handler or furnace control should sense an open state between the Aux #1 and the Aux C terminals.

### 9. Exiting the Test Mode

**NOTE:** While the test mode is active the thermostat will not permit return to the home screen.

- a. To turn the unit off either press the blue down button until “stop test” appears at the bottom of the screen and then press “stop test” on the “installer checkout” screen or open the normally closed switch attached to the air handler or furnace Aux 1 inputs.

**NOTE:** Once the unit is requested to shut down there is a 4 min. delay during which the test mode cannot be changed.

**IMPORTANT:** The minimum run and minimum off timers built into the UODC will be active while operating in the test mode.

- b. Opening the N.C. contact will not exit the test mode, but will permit the system to perform a soft shutdown.
- c. In order for the system to return to normal operating mode press the “Stop” button on the “installer checkout” screen and then press the back arrow in the bottom left hand side of the screen two times. This will return the thermostat to the home screen.



